

---

Client  
Springtree

Date  
3 October 2025

---

# Transport Impact Assessment

## Proposed Mixed-Use Development

57 Stock Route, Mansfield

**ratio:**

**Project**  
57 Stock Route, Mansfield

**Prepared for**  
Springtree

**Our reference**  
22410T

---

**Directory path**      <https://ratioconsultants1.sharepoint.com/sites/22410T/Shared Documents/Work/Reports/22410T-REP01-F04.docx>

---

<b>Version</b>	<b>Date</b>	<b>Issue</b>	<b>Prepared by</b>	<b>Checked by</b>
F01	28.05.2025	Final	S. Lewis	C. Greenland
F02	09.07.2025	Revised Final	C. Hogan	C. Greenland
F03	18.08.2025	Revised Final	C. Hogan	C. Greenland
F05	03.10.2025	Revised Final	C. Hogan	C. Greenland

---

#### **Ratio Consultants Pty Ltd**

This work is copyright. Apart from any use as permitted under Copyright Act 1968, no part may be reproduced without written permission of Ratio Consultants Pty Ltd.

Disclaimer: neither Ratio Consultants Pty Ltd nor any member or employee of Ratio Consultants Pty Ltd takes responsibility in anyway whatsoever to any person or organisation (other than that for which this report is being prepared) in respect of the information set out in this report, including any errors or omissions therein. Ratio Consultants Pty Ltd is not liable for errors in plans, specifications, documentation or other advice not prepared or designed by Ratio Consultants Pty Ltd.

#### **Acknowledgement of Country**

We acknowledge the Traditional Owners of the land we work, live and travel on, and appreciate the rich cultures of the Aboriginal and Torres Strait Islander Peoples and their enduring connection to country.

# Table of Contents

Section	Page No.
1. Introduction	6
1.1. Background	6
1.2. DTP Section 55 – Further Information Request	7
1.3. Structure of this Report	8
1.4. References	8
2. Existing Conditions	9
2.1. Location and Environment	9
2.2. Road Network	11
2.3. Surrounding Intersections	11
2.4. Traffic Volumes	12
2.5. Intersection Analysis	13
2.6. Sustainable Transport	16
2.7. Crash Analysis	17
3. The Proposal	18
3.1. Introduction	18
3.2. Development Plan	18
3.3. Access	19
3.4. Internal Road Network – Residential Village	19
3.5. Car Parking Provision – Residential Village	20
3.6. Pedestrian and Bicycle Connectivity – Residential Village	20
3.7. Childcare Centre Information	20
4. Car Parking Assessment	22

4.1.	Planning Scheme Assessment	22
4.2.	Proposed Car Parking Provision	23
4.3.	Car Parking Spaces for People with Disabilities	23
5.	Access Arrangements & Car Parking Layout	25
5.1.	Clause 52.06 Design Standard Assessment	25
5.2.	Swept Path Assessment	27
6.	Bicycle Parking Assessment	28
6.1.	Clause 52.34 - Bicycle Facilities	28
7.	Loading and Waste Collection	29
7.1.	Statutory Requirement	29
7.2.	Loading and Waste Collection Arrangements	29
7.3.	Adequacy of Loading and Waste Collection Arrangements	30
8.	Traffic Assessment	31
8.1.	Traffic Generation	31
8.2.	Traffic Distribution	34
8.3.	Post Development Traffic Volumes	34
8.4.	Intersection Analysis	35
8.5.	Highway Intersections - 10-Year Post Development Assessment	38
8.6.	Turn Warrant Treatments	40
9.	Conclusion	43

## Appendices

Appendix A - Development Plans

Appendix B - Traffic Survey Data

Appendix C - Existing Conditions SIDRA Results

---

Appendix D – Swept Path Assessment

---

Appendix E – Post Development SIDRA Results

---

Appendix F – 10-Year Post Development SIDRA Results

---

## Table of Figures

Figure 1.1: Site Layout	6
Figure 2.1: Site Location	9
Figure 2.2: Aerial View of the Subject Site and Surrounds	10
Figure 2.3: Planning Scheme Land Zoning	10
Figure 2.4: Stock Route facing North	11
Figure 2.5: Peak Hour Traffic Survey Results	12
Figure 2.6: Existing Peak Hour Turning Movements	13
Figure 3.1: Site Location	18
Figure 3.2: Proposed Site Access Arrangement	19
Figure 8.1: Traffic Distribution	34
Figure 8.2: Post Development Traffic Volumes	35
Figure 8.3: 10 Year Post Development Traffic Volumes	39
Figure 8.4: Calculation for Major Road Traffic Volume	41
Figure 8.5: Warrants for turn treatments - Dead Horse Lane / Midland Highway	42

## Table of Tables

Table 2.1: Ratings of Degree of Saturation (DoS)	13
Table 2.2: Existing Peak SIDRA – Stock Route / Dead Horse Lane Intersection	14
Table 2.3: Existing Peak SIDRA – Withers Lane / Dead Horse Lane Intersection	14

---

Table 2.4: Existing Peak SIDRA – Withers Lane / Maroondah Highway Intersection	15
Table 2.5: Existing Peak SIDRA – Dead Horse Lane / Midland Highway Intersection	16
Table 3.1: Childcare Centre Information	21
Table 4.1: Statutory Car Parking Requirement	22
Table 4.2: BCA Car Parking Requirement	24
Table 5.1: Design Standard 1 - Accessways	25
Table 5.2: Design Standard 2 - Car Parking Spaces	26
Table 8.1: Case Study Traffic Generation Rates	31
Table 8.2: Projected Traffic Generation – Residential Village	33
Table 8.3: Projected Traffic Generation – Childcare Centre	33
Table 8.4: Total Projected Traffic Generation	34
Table 8.5: Post Development Peak SIDRA – Stock Route / Dead Horse Lane Intersection	35
Table 8.6: Post Development Peak SIDRA – Withers Lane / Dead Horse Lane Intersection	36
Table 8.7: Post Development Peak SIDRA – Withers Lane / Maroondah Highway Intersection	37
Table 8.8: Post Development Peak SIDRA – Dead Horse Lane / Midland Highway	37
Table 8.9: 10 Year Post Development Peak SIDRA - Withers Lane / Maroondah Highway	39
Table 8.10: 10 Year Post Development Peak SIDRA - Dead Horse Lane / Midland Highway	40

---

# 1. Introduction

## 1.1. Background

Ratio Consultants prepared a Transport Impact Assessment Report (22410T-REP01-F01) to assess the planning application submitted for the development of the site at 57 Stock Route in Mansfield.

The proposed development seeks to construct a residential village (over 55's land lease community) catering for 177 homes, with associated facilities including a clubhouse / community centre and a WSUD/caravan area.

In addition to the residential village, a lot is proposed in the south-east corner of the subject site. The lot is proposed to consist of a childcare centre suitable for catering for up to 164 children. The scale and layout are consistent with the childcare centre that was approved as part of the Planning Permit for the site (Permit No. P135/22).

For reference, an excerpt of the site plan is provided in Figure 1.1, with a copy of the development plans also provided in Appendix A of this report.

Figure 1.1: Site Layout

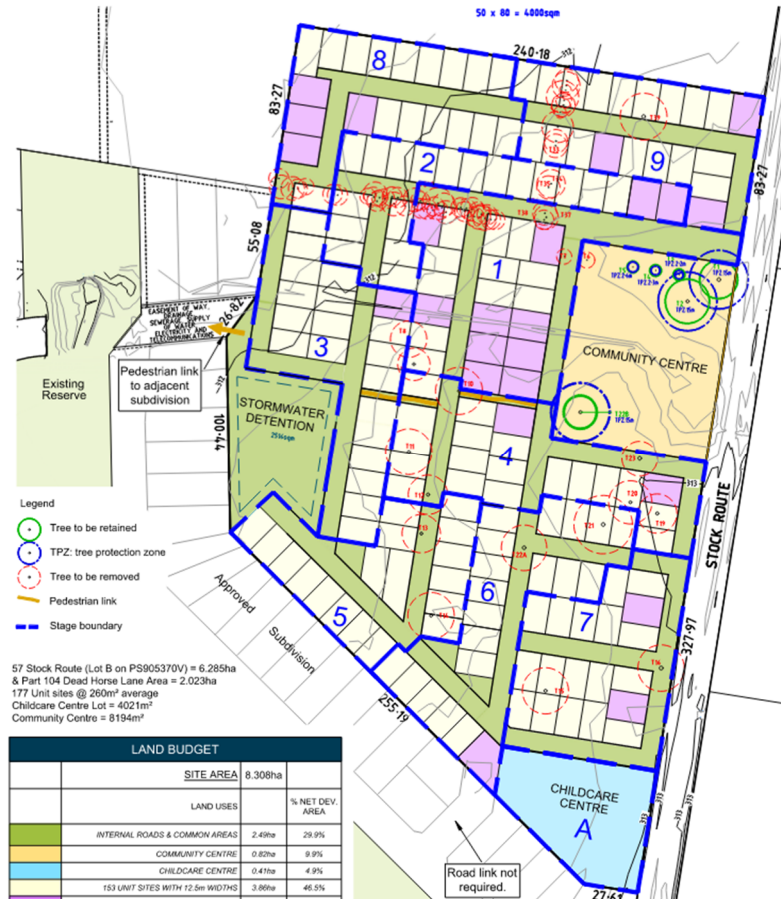

Source: Millar & Merrigan Pty Ltd

## 1.2. DTP Section 55 – Further Information Request

### First DTP Further Information Request (18 June 2025)

Upon review of the submission, the Department of Transport and Planning (DTP) issued a Section 55 – Further Information Request (dated 18 June 2025) in response to the application and the accompanying TIA report.

DTP requested the following additional information:

1. *A revised TIAR that includes a justification of the traffic generation assumptions, supported by an assessment of comparable developments or relevant case studies. Where it is determined that the case studies relied upon are not directly comparable to the proposed development, standard traffic generation rates should be applied.*
2. *A revised TIAR that applies appropriate growth factors to the March 2023 traffic survey data, reflecting background traffic growth over the past 27 months to ensure the analysis accurately represents current conditions. Alternatively, updated traffic survey data should be sourced and provided.*
3. *A revised TIAR that thoroughly evaluates the accurate anticipated future conditions at the key intersections identified in the report.*
4. *A revised TIAR that provides a 10-year post-development assessment to appropriately account for future traffic impacts. This analysis should clearly incorporate a justified and appropriate traffic growth factor.*
5. *Electronic copy of the SIDRA modelling. This will need to be reflective of any changes required as a result of this request for further information.*
6. *A revised TIAR that provides a turn warrant assessment of existing traffic conditions at the key intersections identified in the report, and a comprehensive 10-year post-development turn warrant analysis for these intersections, to evaluate the need for any turn treatments or intersection upgrades. This analysis should clearly incorporate a justified and appropriate traffic growth factor.*

A revised TIA report was prepared to address each request from DTP listed above. Specifically, each numbered request was addressed in the following sections:

- 1 (justification of traffic generation assumptions): Section 8.1.
- 2 (background traffic growth since March 2023 surveys): Section 2.4.
- 3 (analysis of key intersections): Section 8.4.
- 4 (10-year post development assessment of key intersections): Section 8.5.
- 5 (provision of electronic SIDRA modelling file): To be provided separately to the traffic report as requested.
- 6 (turn warrant assessment): Section 8.6.

### Second DTP Further Information Request (24 September 2025)

Following the receipt of the revised TIA addressing each of DTP's queries, a follow-up request for further information was issued by DTP (dated 24/09/2025).

The request stated:

*A Transport impact Assessment replying to this was received on the 24th of September 2025. The case studies may not be fully comparable to Mansfield, as the Victorian sites are in metropolitan Melbourne with better public transport. We also note that NSW sites may not be comparable, but we support the assumption that many will not use cars during peak periods.*

*Please provide further analysis to support the PM peak of 0.23*

As such, a revised analysis of the traffic generation has been undertaken which includes reference to a case study of the 'Lifestyle Village' located at 17 Booker Rise in Bittern. This site is in a regional location similar to Mansfield with similar opportunities to Public Transport.

This assessment is presented in Section 8.1 (traffic generation) of this report.

### 1.3. Structure of this Report

This report sets out an assessment of the anticipated parking, traffic and transport implications of the proposed development, including consideration of the:

- Existing traffic conditions surrounding the site.
- Parking demand likely to be generated by the proposed development.
- Suitability of the proposed parking in terms of supply and layout.
- Traffic generation characteristics of the proposed development.
- Proposed access arrangements for the site.
- Transport impact of the development proposal on the surrounding road network.

### 1.4. References

In preparing this report, reference has been made to the following:

- Plans for the development prepared by Millar & Merrigan Pty Ltd, attached as Appendix A.
- Section 55 further information request issued by the Department of Transport and Planning.
- Mansfield Shire Planning Scheme.
- Australian/ New Zealand Standard, Parking Facilities Part 1: Off-Street Car Parking (AS/NZS2890.1:2004).
- Australian Standard, Parking Facilities Part 2: Off-Street Commercial Vehicle Facilities (AS2890.2:2018)
- Australian/ New Zealand Standard, Parking Facilities Part 6: Off-Street Car Parking for People with Disabilities (AS/NZS2890.6:2015).
- Traffic surveys as detailed within this report.
- An inspection of the subject site and surrounds.
- Other documents as nominated.

# 2. Existing Conditions

## 2.1. Location and Environment

The subject site(s) of 57 Stock Route and 104 Dead Horse Lane in Mansfield feature road frontages to Stock Route along the eastern site boundaries, with a minor frontage to Stockmans Drive at the western boundary – noting the extension of Stockmans Drive is approved but is yet to be constructed.

The site location is shown in Figure 2.1 with an aerial provided in Figure 2.2.

Figure 2.1: Site Location

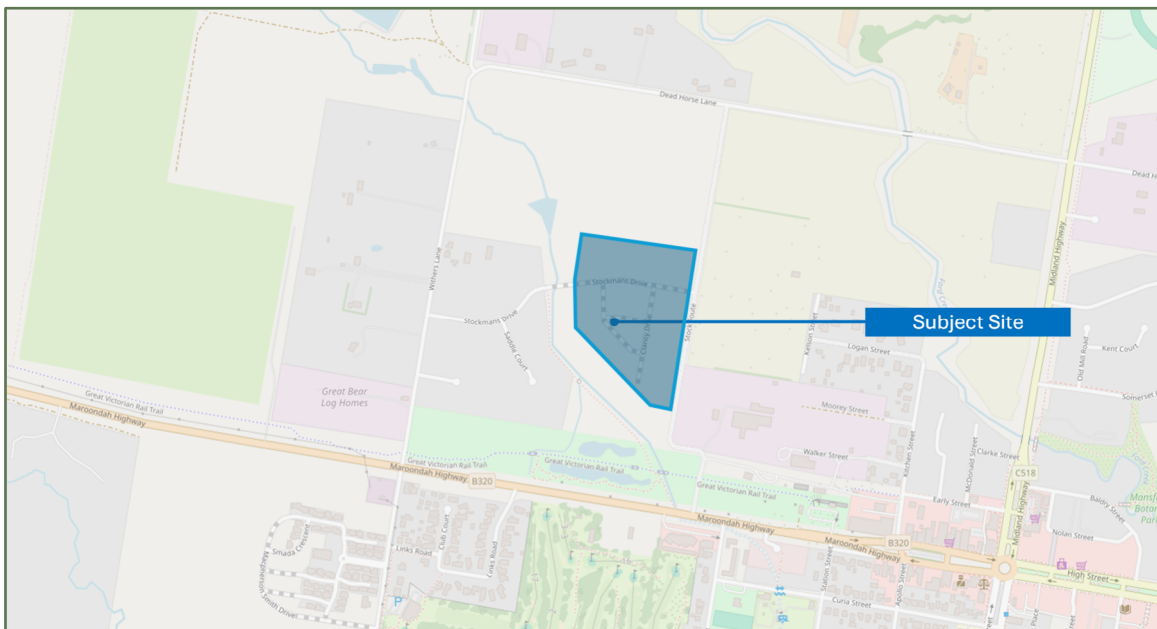

Source: Melways

Figure 2.2: Aerial View of the Subject Site and Surrounds



Source: Nearmap

The subject site is irregular in shape and features an approximate area of 8.29 hectares (consolidated area between 57 Stock Route & 104 Dead Horse Lane). The site(s) are currently occupied by a single shed but are otherwise vacant.

Land use surrounding the site generally comprises a mix of vacant lots and residential land, with the Mansfield town centre area situated approximately 1km southeast of the development site.

The subject site land zoning is depicted in Figure 2.3.

Figure 2.3: Planning Scheme Land Zoning

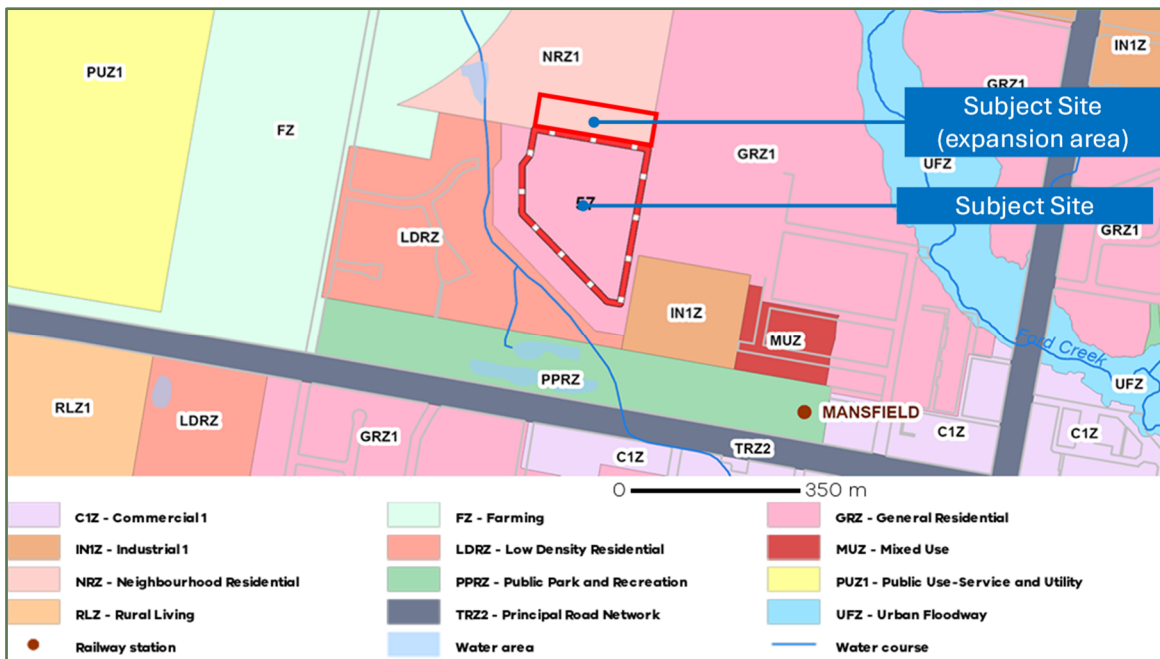

Source: VicPlan

The development site is situated within both a General Residential Zone – Schedule 1 (GRZ1) and Neighbourhood Residential Zone – Schedule 1 (NRZ1). The adjacent land parcel at 104 Dead Horse Lane is subject to a Land Subject to Inundation Overlay (LSIO). Accordingly, no applicable transport overlays have been observed to affect the site.

## 2.2. Road Network

**Stock Route** is under the jurisdiction of Mansfield Shire Council and is classified as a Rural Paved (unsealed) road in accordance with the Mansfield Shire Council Register of Public Roads (August 2024).

The road is aligned in a north south direction between Dead Horse Lane in the north and Maroondah Highway in the south and generally features a 20-metre cross-section which accommodates an unsealed, 5.5 metre wide roadway. No footpaths are provided on either side of the carriageway.

A typical view of Stock Route is provided in Figure 2.4.

**Figure 2.4: Stock Route facing North**



Source: VicPlan

## 2.3. Surrounding Intersections

Key intersections within the vicinity of the subject site include:

- Stock Route / Maroondah Highway (unsignalised intersection).
- Stock Route / Dead Horse Lane (unsignalised intersection).
- Midland Highway / Dead Horse Lane (unsignalised intersection).
- Withers Lane / Dead Horse Lane (unsignalised intersection).
- Withers Lane / Maroondah Highway (unsignalised intersection).

## 2.4. Traffic Volumes

### Surveyed Volumes

To establish baseline traffic conditions within the vicinity of the subject site, Ratio commissioned turning movement counts at the following intersections:

- Stock Route / Dead Horse Lane.
- Midland Highway / Dead Horse Lane.
- Withers Lane / Dead Horse Lane.
- Withers Lane / Maroondah Highway.

The preceding intersections were surveyed during the following periods:

- Tuesday 28 March 2023: 7:00am – 10:00am.
- Tuesday 28 March 2023: 3:00pm – 6:00pm.

The peak hour turning movements are shown in Figure 2.5 and are attached in full as Appendix B of this report.

**Figure 2.5: Peak Hour Traffic Survey Results**

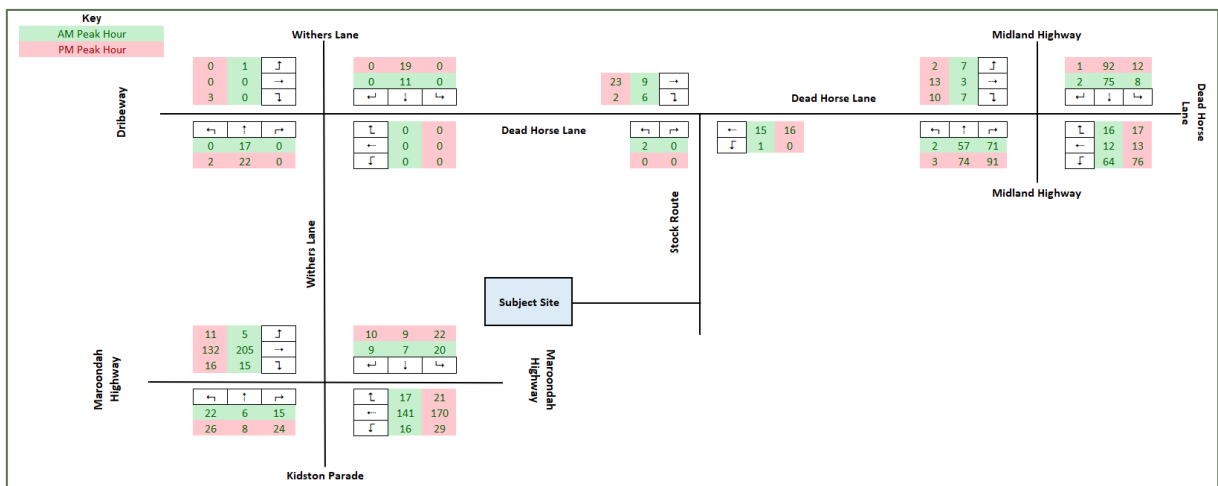

### Background Traffic Growth

Background traffic growth since these surveys were undertaken in March 2023 (27 months) has been considered.

The Mansfield Shire Council website indicates that population growth within the municipality is approximately 2% each year. As such, a 2% accumulative growth rate has been applied to the through volumes on Maroondah Highway and Midland Highway over 27 months (2 ¼ years).

The peak hour turning movements with the above-described growth on Maroondah Highway and Midland Highway applied are illustrated in Figure 2.6.

Figure 2.6: Existing Peak Hour Turning Movements

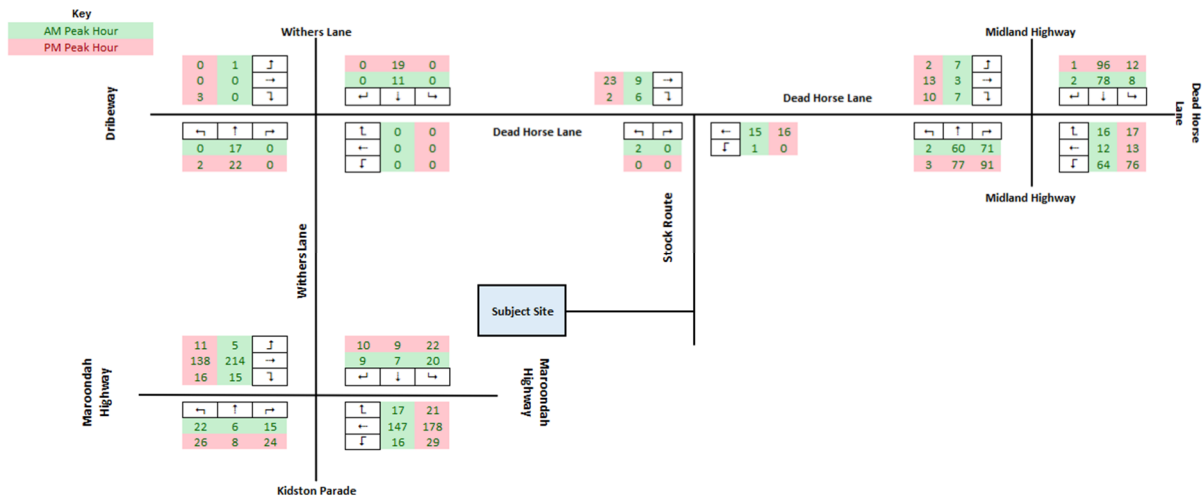

## 2.5. Intersection Analysis

### General

An existing conditions peak hour intersection analysis has been undertaken of the following intersections, using the analysis program SIDRA Intersection:

- Stock Route / Dead Horse Lane intersection.
- Withers Lane / Dead Horse Lane intersection.
- Withers Lane / Maroondah Highway intersection.
- Dead Horse Lane / Midland Highway intersection.

### SIDRA Parameters

The key parameters used to determine the operational capacity of an intersection are queue length, average delay and degree of saturation (or volume to capacity ratio).

Degree of Saturation (DOS) is a ratio of arrival (or demand) flow to capacity. DOS above 1.0 represent oversaturated conditions and a DOS below 1.0 represent undersaturated conditions.

The operational rating associated with the DOS is summarised in Table 2.1.

Table 2.1: Ratings of Degree of Saturation (DoS)

Degree of Saturation (DoS)	Rating
Up to 0.6	Excellent
0.61 – 0.70	Very Good
0.71 – 0.80	Good
0.81 – 0.90	Fair
0.91 – 1.00	Poor
Greater than 1.00	Very Poor

Although operating conditions with a degree of saturation around 1.00 are undesirable, it is acknowledged that this level of congestion is typical of many metropolitan intersections during the AM and PM peak hours.

The 95th percentile queue length is the value below which 95 percent of all observed cycle queue lengths fall, or 5 percent of all observed queue lengths exceed.

Average Delay is the average time, in seconds, that all vehicles making a particular movement can expect to wait at an intersection.

### Stock Route / Dead Horse Lane

The results for the existing peak hour intersection analysis for the Stock Route / Dead Horse Lane intersection are summarised in Table 2.2, with full results provided as Appendix C.

**Table 2.2: Existing Peak SIDRA - Stock Route / Dead Horse Lane Intersection**

Approach	Movement	AM Peak Hour			PM Peak Hour		
		DoS	95%ile Queue (m)	Average Delay (s)	DoS	95%ile Queue (m)	Average Delay (s)
Stock Route	Left	0.01	1	6	0.01	0	6
	Right	0.01	1	6	0.01	0	6
Dead Horse Lane (E)	Left	0.01	0	6	0.01	0	6
	Through	0.01	0	0	0.01	0	0
Dead Horse Lane (W)	Through	0.01	1	0	0.01	1	0
	Right	0.01	1	6	0.01	1	6
<b>Intersection</b>		<b>0.01</b>			<b>0.01</b>		

Based on the above, the Stock Route / Dead Horse Lane intersection is currently operating within 'Excellent' conditions in the AM and PM peak hour, with minimal queues and delays projected.

### Withers Lane / Dead Horse Lane

The results for the existing peak hour intersection analysis for the Withers Lane / Dead Horse Lane intersection are summarised in Table 2.3, with full results provided as Appendix C.

**Table 2.3: Existing Peak SIDRA - Withers Lane / Dead Horse Lane Intersection**

Approach	Movement	AM Peak Hour			PM Peak Hour		
		DoS	95%ile Queue (m)	Average Delay (s)	DoS	95%ile Queue (m)	Average Delay (s)
Withers Lane (S)	Left	0.01	1	6	0.01	1	6
	Through	0.01	1	0	0.01	1	0
	Right	0.01	1	6	0.01	1	6

Dead Horse Lane	Left	0.01	1	6	0.01	1	6
	Through	0.01	1	4	0.01	1	4
	Right	0.01	1	6	0.01	1	6
Withers Lane (N)	Left	0.01	1	6	0.01	1	6
	Through	0.01	1	0	0.01	1	0
	Right	0.01	1	6	0.01	1	6
Local Driveway	Left	0.01	1	6	0.01	1	6
	Through	0.01	1	4	0.01	1	4
	Right	0.01	1	6	0.01	1	6
<b>Intersection</b>		<b>0.01</b>			<b>0.01</b>		

Based on the above, the Withers Lane / Dead Horse Lane intersection is currently operating at 'Excellent' conditions in the AM and PM peak hour, with minimal queues and delays projected.

### Withers Lane / Maroondah Highway

The results for the existing peak hour intersection analysis for the Withers Lane / Maroondah Highway intersection are summarised in Table 2.4, with full results provided as Appendix C.

**Table 2.4: Existing Peak SIDRA - Withers Lane / Maroondah Highway Intersection**

Approach	Movement	AM Peak Hour			PM Peak Hour		
		DoS	95%ile Queue (m)	Average Delay (s)	DoS	95%ile Queue (m)	Average Delay (s)
Kidston Parade	Left	0.05	1	9	0.08	2	9
	Through	0.05	1	10	0.08	2	10
	Right	0.05	1	11	0.08	2	11
Maroondah Highway (E)	Left	0.10	1	6	0.13	1	6
	Through	0.10	1	0	0.13	1	1
	Right	0.10	1	6	0.13	1	6
Withers Lane	Left	0.05	1	9	0.05	1	9
	Through	0.05	1	10	0.05	1	10
	Right	0.05	1	11	0.05	1	11
Maroondah Highway (W)	Left	0.13	1	6	0.09	1	6
	Through	0.13	1	0	0.09	1	0
	Right	0.13	1	6	0.09	1	6
<b>Intersection</b>		<b>0.13</b>			<b>0.13</b>		

Based on the above, the Withers Lane / Maroondah Highway intersection is currently operating within 'Excellent' conditions in the AM and PM peak hour, with minimal queues and delays projected.

### Dead Horse Lane / Midland Highway

The results for the existing peak hour intersection analysis for the Dead Horse Lane / Midland Highway intersection are summarised in Table 2.5, with full results provided as Appendix C.

**Table 2.5: Existing Peak SIDRA – Dead Horse Lane / Midland Highway Intersection**

Approach	Movement	AM Peak Hour			PM Peak Hour		
		DoS	95%ile Queue (m)	Average Delay (s)	DoS	95%ile Queue (m)	Average Delay (s)
Midland Highway (S)	Left	0.08	3	6	0.10	3	6
	Through	0.08	3	0	0.10	3	0
	Right	0.08	3	6	0.10	3	6
Dead Horse Lane (E)	Left	0.08	2	6	0.09	3	6
	Through	0.08	2	5	0.09	3	6
	Right	0.08	2	7	0.09	3	7
Midland Highway (N)	Left	0.05	0	6	0.06	0	6
	Through	0.05	0	0	0.06	0	0
	Right	0.05	0	6	0.06	0	6
Dead Horse Lane (W)	Left	0.02	0	6	0.03	1	6
	Through	0.02	0	5	0.03	1	5
	Right	0.02	0	7	0.03	1	8
<b>Intersection</b>		<b>0.08</b>			<b>0.10</b>		

Based on the above, the Dead Horse Lane / Midland Highway intersection is currently operating within 'Excellent' conditions in the AM and PM peak hour, with minimal queues and delays projected.

## 2.6. Sustainable Transport

### Public Transport

The subject site currently has low-level access to surrounding public transport facilities.

The closest bus service (Mansfield – Melbourne via Yea) operate along High Street, with the closest bus stop located approximately 750 metres south-east of the subject site.

### Bicycle and Pedestrian Network

Pedestrian access to the site is currently limited with no pedestrian paths currently provided along the site's frontages.

Cyclist infrastructure in the vicinity of the subject site is limited to the Great Victorian Rail Trail located adjacent to Maroondah Highway.

## 2.7. Crash Analysis

A review has been conducted of the VicRoads 'CrashStats' database for the five-year period of available data for any reported casualty crashes. The database records all accidents causing injury that have occurred in Victoria since 1987 (as recorded by Victorian Police) and categorises these accidents as follows:

*Fatal Injury: At least one person was killed in the accident or died within 30 days as a result of the accident.*

*Serious Injury: At least one person is sent to Hospital as a result of the accident.*

*Other Injury: At least one person required medical treatment as a result of the accident.*

Having undertaken a review of the roads proximate to the development site, including the intersections listed within the preceding sections, no reported casualty crashes have been identified within the last 5 years.

Accordingly, the crash analysis suggests there are no existing road safety issues within the surrounding road network.

# 3. The Proposal

## 3.1. Introduction

The proposal seeks to subdivide the land into a residential village (over 55's land lease community) and a childcare centre. The following discussion reviews the residential and childcare centre components separately.

## 3.2. Development Plan

The development proposes to construct a residential village catering for 177 homes, with associated facilities including a clubhouse / community centre and a WSUD/caravan area.

In addition to the residential village, it is proposed to construct a childcare centre catering for up to 164 children. The scale and layout are generally consistent with the childcare centre that was approved as part of the Planning Permit for the site (Permit No. P135/22).

For reference, an excerpt of the site plan is provided in Figure 3.1, with a copy of the development plans also provided in Appendix A of this report.

Figure 3.1: Site Location

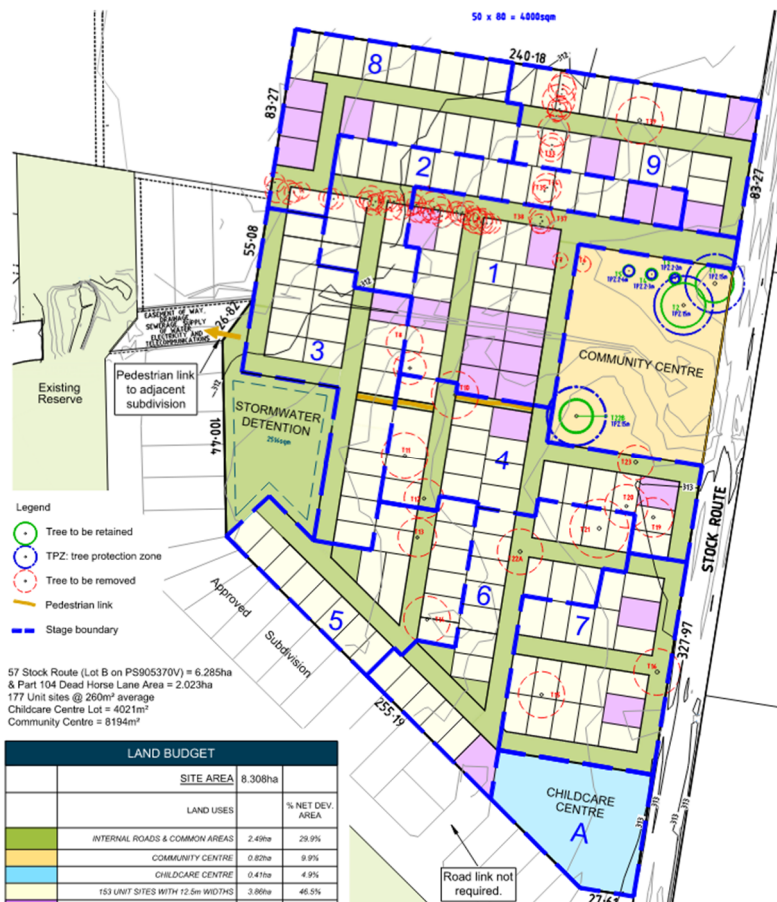

Source: Millar & Merrigan Pty Ltd

### 3.3. Access

Vehicle access to the residential village component is proposed to be taken via Stock Route along the eastern boundary of the subject site. Two separate vehicle access points to Stock Route are provided for the childcare centre (one ingress only and one egress only). The proposed access arrangements are shown in Figure 3.2 with the proposed site layout plan.

Figure 3.2: Proposed Site Access Arrangement

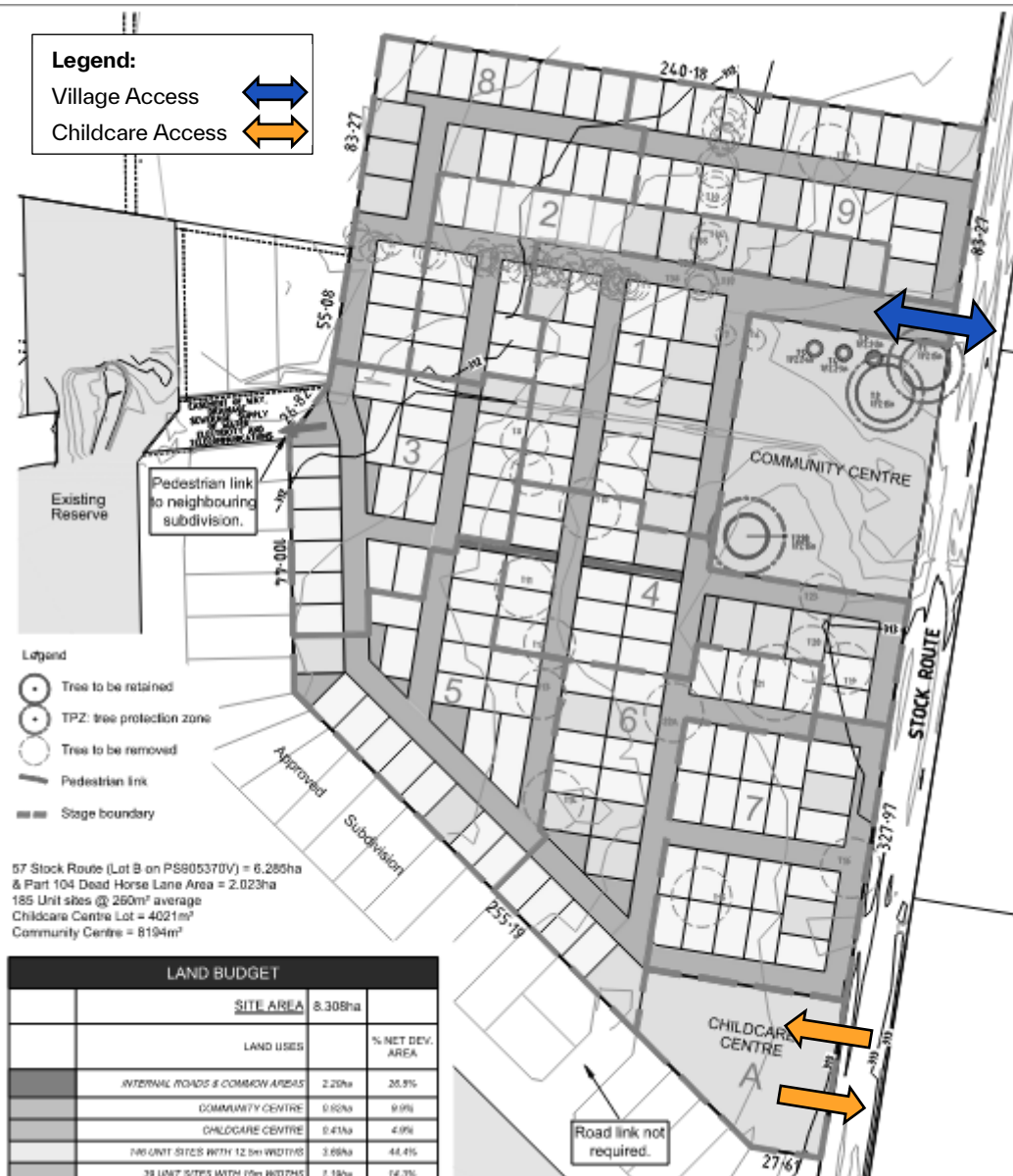

### 3.4. Internal Road Network – Residential Village

The internal road network of the residential village will comprise 10-metre-wide cross sections with 5.5m wide carriageways. The carriageways will operate as shared zones accommodating pedestrian movements in addition to vehicle movements.

### 3.5. Car Parking Provision – Residential Village

#### Resident Parking

Each dwelling will be provided with car parking within a garage as well as space within the driveway behind the garage to accommodate another space in tandem.

Most dwellings are provided with a single garage and are therefore provided with 2 car spaces (1 x in the garage and 1 x in the driveway).

Some of the three-bedroom dwellings are provided with double garages and therefore can accommodate up to 4 car spaces (2 x in the garage and 2 x in the driveway).

Indented kerbside parking will also be provided along the frontages of the internal common areas for use by residents accessing the common areas.

#### Community Centre Parking

The community centre will be serviced by 17 car spaces accessed directly from the internal roads fronting it (7 x indented spaces, 10 x 90-degree spaces).

#### Resident Visitor Parking

Resident visitor parking will be accommodated kerbside within the internal road network of the residential village, with the 5.5 metre wide road carriageway capable accommodating parking on one side.

### 3.6. Pedestrian and Bicycle Connectivity – Residential Village

#### Pedestrian and Bicycle Network

As mentioned in Section 3.4, the internal road network will operate as a shared zone with pedestrian movements accommodated within the road carriageway. Any bicycle movements will also be accommodated within the carriageway, in addition to vehicle and pedestrian movements.

### 3.7. Childcare Centre Information

A lot is proposed in the south-east corner of the subject site consisting of a childcare centre suitable for catering for up to 164 children. The scale and layout are consistent with the childcare centre that was approved as part of the Planning Permit for the site (Permit No. P135/22).

More specifically, the Childcare Centre development will incorporate the following land use yield and associate transport infrastructure, as summarised in Table 3.1.

Table 3.1: Childcare Centre Information

Land Use		
Land Use Clarification	Description	Size / No.
Childcare Centre	Childcare Centre	164 children
Transport Infrastructure		
Type	Description	Size / No.
Pedestrian Access	Along eastern boundary	-
Vehicle Access	Stock Route Northern Access	Ingress Only
	Stock Route Southern Access	Egress Only
Parking	Car Spaces	36 spaces [1]
Loading	Loading	SRV up to 6.4m long

[1] Consisting of 34 standard car parking spaces, 1 parking space for people with disabilities and 1 parallel (drop off) car parking space.

# 4. Car Parking Assessment

## 4.1. Planning Scheme Assessment

Parking requirements for the proposed development are set out under Clause 52.06 of the Mansfield Shire Planning Scheme. The purpose of Clause 52.06, amongst other things, is:

- *To ensure that car parking is provided in accordance with the Municipal Planning Strategy and the Planning Policy Framework.*
- *To ensure the provision of an appropriate number of car parking spaces having regard to the demand likely to be generated, the activities on the land and the nature of the locality.*
- *To support sustainable transport alternatives to the motor car.*
- *To promote the efficient use of car parking spaces through the consolidation of car parking facilities.*
- *To ensure that car parking does not adversely affect the amenity of the locality.*
- *To ensure that the design and location of car parking is of a high standard, creates a safe environment for users and enables easy and efficient use.*

The number of parking spaces required for specific uses is listed in Table 1 of the Mansfield Planning Scheme. The parking requirement specified for a use as listed in Table 1 does apply if:

- *A car parking requirement for the use is specified under another provision of the planning scheme; or,*
- *A schedule to the Parking Overlay specifies the number of car parking spaces required for the use.*

The statutory car parking requirement is subsequently set out in Table 4.1.

**Table 4.1: Statutory Car Parking Requirement**

Use	Description	Number	Statutory Parking Rate	Requirement
Residential	One-Bed	177 lots [1]	1 to each one or two bed	177-354 spaces [1]
	Two-Bed		2 to each three or more bed	
	Three-Bed			
	Visitor		1 to every 5 dwellings	36 spaces
Childcare Centre		164 children	0.22 spaces per child	36 spaces
<b>Total</b>				<b>249-426 spaces</b>

*[1] As per the Development Plans, the actual breakdown of one-, two- and three-bedroom dwellings has not yet been resolved. As such, a range has been presented between if all dwellings have no more than 2 bedrooms (stat rate of 1 space per dwelling) and if all dwellings have at least 3 bedrooms (stat rate of 2 spaces per dwelling).*

Based on the above table, the development has a statutory requirement between 249-426 car parking spaces including 177-354 resident spaces, 36 residential visitor spaces and 36 childcare centre spaces.

## 4.2. Proposed Car Parking Provision

### Residents

As outlined in Section 3.5, all dwellings will be provided with at least 2 on-site car spaces each, thereby either exceeding or satisfying the statutory requirement, depending on the mix of bedrooms to each lot.

### Residential Community Centre

It is understood that the community centre will be exclusively for the use of residents of the village and is considered ancillary to the village.

This arrangement is typical for retirement villages and communal recreational facilities are specified as ancillary under the retirement village land use in Clause 73.03 of the Planning Scheme.

While the proposed residential village is not a retirement village, but rather is for over 55s, the community centre will operate as per a typical ancillary facility for a retirement village and will not generate its own parking demand.

Notwithstanding, there is indented parking along the road frontages capable of accommodating up to 17 cars.

### Residential Visitors

No dedicated visitor parking spaces are proposed within the development. Instead, visitor parking demand is expected to be accommodated informally via available on-street parking.

The internal road network has been designed with 5.5-metre-wide carriageways, allowing for vehicle parking on one side of the street while still maintaining adequate access. This arrangement provides sufficient opportunities to accommodate visitor parking demand.

### Childcare Centre

Consistent with the approved scheme (Permit No. P135/22), the proposal includes the provision of 36 car parking spaces and therefore satisfies the statutory car parking requirement specified by Clause 52.06-5 of the Mansfield Shire Planning Scheme.

## 4.3. Car Parking Spaces for People with Disabilities

In addition to the statutory car parking requirements in the Planning Scheme, the Building Code of Australia (BCA) outlines the requirements for the provision of car parking for people with disabilities.

An assessment of the BCA disabled car parking requirements for the childcare centre component of the development is outlined in Table 4.2.

Table 4.2: BCA Car Parking Requirement

Description	Use	BCA Disabled Parking Requirements
Childcare Centre	Childcare Centre	1 space for every 50 car parking spaces or part thereof

Parking spaces for people with disabilities can be included in the total number of spaces required by the Planning Scheme. The on-site provision of one space for people with a disability meets the BCA requirement and is considered appropriate.

# 5. Access Arrangements & Car Parking Layout

## 5.1. Clause 52.06 Design Standard Assessment

### Design Standard 1 - Accessways

Design Standard 1 of Clause 52.06-9 relates to the design of accessways. The requirements of Design Standard 1 are assessed against the proposal in Table 5.1.

Table 5.1: Design Standard 1 - Accessways

Requirement	Comments
Must be at least 3 metres wide	<b>Satisfied</b> – Access road to Stock Route (16m road reserve) has opposing traffic in separate carriageways with 3.5m wide trafficable lanes.
Have an internal radius of at least 4 metres at changes of direction or intersection or be at least 4.2 metres wide.	<b>Satisfied</b> – Internal roads (10m road reserve) have 5.5m wide carriageways.
Allow vehicles parked in the last space of a dead-end accessway in public car parks to exit in a forward direction with one manoeuvre.	<b>N/A</b> – the lifestyle village is a private estate.
Provide at least 2.1 metres headroom beneath overhead obstructions, calculated for a vehicle with a wheelbase of 2.8 metres.	<b>Satisfied</b> – No overhead obstructions along internal roads of less than 2.1m.
If the accessway serves four or more car spaces or connects to a road in a Transport Zone 2 or Transport Zone 3, the accessway must be designed so that cars can exit the site in a forward direction.	<b>Satisfied</b> – All cars can enter and exit the village in a forward direction.
Provide a passing area at the entrance at least 6.1 metres wide and 7 metres long if the accessway serves ten or more car parking spaces and is either more than 50 metres long or connects to a road in a Transport Zone 2 or Transport Zone 3.	<b>Satisfied</b> – Opposing traffic is provided in separate carriageways.
Have a corner splay or area at least 50% clear of visual obstructions extending at least 2 metres	<b>Satisfied</b> – Sight lines are clear as per the sight splay requirements.

along the frontage road from the edge of an exit land and 2.5 metres along the exit lane from the frontage, to provide a clear view of pedestrians on the footpath of the frontage road. The area clear of visual obstructions may include an adjacent entry or exit lane where more than one lane is provided, or adjacent landscaped areas, provided the landscaping in those areas is less than 900mm in height.

If an accessway to four or more car parking spaces is from land in a Transport Zone 2 or Transport Zone **N/A** – Accessway is not from land in a TR22 or 3, the access to the car spaces must be at least 6 metres from the road carriageway. **TRZ3.**

If entry to the car space is from a road, the width of the accessway may include the road. **N/A** – Entry to car spaces is not accessed directly from an external road.

## Design Standard 2 – Car Parking Spaces

Design Standard 2 of Clause 52.06-9 relates to the design of car parking spaces. The requirements of Design Standard 2 are assessed against the proposal in Table 5.2.

**Table 5.2: Design Standard 2 - Car Parking Spaces**

Requirement	Comments
Car parking spaces and accessways must have the minimum dimensions as outlined in Table 2 of Design Standard 2.	<b>Satisfactory</b> – Indented parking along community centre frontage is provided at approximately 2.5m width and 6.4m length, in excess of the minimum requirements as defined in the Australian Standards.
A wall, fence, column, tree or tree guard or any other structure that abuts a car space must not encroach into the area marked ‘clearance required’ on Diagram 1 of Design Standard 2, other than: <ul style="list-style-type: none"> <li>– A column, tree or tree guard, which may project into a space if it is within the area marked ‘tree or column permitted’ on Diagram</li> <li>– A structure, which may project into the space if it is at least 2.1 metres above the space.</li> </ul>	<b>N/A</b> – No car spaces external to garages.
Car spaces in garages or carports must be at least 6 metres long and 3.5 metres wide for a single space and 5.5 metres wide for a double space measured inside the garage or carport.	<b>Satisfied</b> – All garages are provided with more than 6m length.

---

Single garages are provided with widths of approximately 3.6m, while double garages are provided with widths of approximately 6m.

---

Where parking spaces are provided in tandem (one space behind the other) an additional 500mm in length must be provided between each space.

**Satisfied** – Single garages servicing 3 bedroom dwellings have space to accommodate a car in tandem behind the garage.

While plans show these garages offset from the road reserve by 4m, there is another 2.25m prior to the carriageway. As there are no footpaths proposed within the road reserves, these driveway lengths are 6.25m long and can comfortably support the required car space length and additional 500mm ( $4.9 + 0.5 = 5.4\text{m}$ ).

---

Where two or more car parking spaces are provided for a dwelling, at least one space must be under cover.

**Satisfied** – All dwellings with two car spaces have at least one space within a garage.

---

Disabled car parking spaces must be designed in accordance with Australian Standard AS2890.6-2009 (disabled) and the Building Code of Australia. Disabled car parking spaces may encroach into an accessway width specified in Table 2 by 500mm.

**N/A** – No DDA spaces proposed

---

## 5.2. Swept Path Assessment

An assessment (refer to Appendix D) of the circulation of the village's internal road network using the 'Autodesk Vehicle Tracking' software has been conducted. The 8.8m Medium Rigid Vehicle (MRV) was used in the assessment and it was demonstrated circulation could be achieved in a satisfactory manner.

# 6. Bicycle Parking Assessment

## 6.1. Clause 52.34 – Bicycle Facilities

Clause 52.34 of the Mansfield Shire Planning Scheme does not specify statutory bicycle parking requirements for a residential village or childcare centre land uses.

Given the nature of the proposed use and location of the subject site, it is unlikely that there will be demand for bicycle parking for the proposed development.

Having regard to the above, a provision of zero on-site bicycle parking spaces is considered adequate in this instance.

# 7. Loading and Waste Collection

## 7.1. Statutory Requirement

Clause 65.01 'Decision Guidelines' of the Mansfield Shire Planning Scheme outlines the provision of loading requirements, and states the following:

*"Before deciding on an application or approval of a plan, the responsible authority must consider, as appropriate:*

- *The adequacy of loading and unloading facilities and any associated amenity, traffic flow and road safety impacts."*

## 7.2. Loading and Waste Collection Arrangements

### Residential Village

Loading and unloading activities with the residential village component of the proposal will be associated with small deliveries to the community centre, which are expected to be infrequent and completed by relatively small delivery vehicles.

Furthermore, it is understood that waste bins for the dwellings will be collected from within the site by Council waste collection.

It is proposed that the largest vehicle to access the site will be an 8.8-metre-long medium rigid vehicle (MRV as defined by AS2890.2:2018).

Swept paths indicate that an MRV can enter the site, circulate each of the internal roadways before exiting the site in a forward direction. It is noted that the MRV is required to use the full width of the roadway when turning around bends or at intersections within the site.

This arrangement is considered acceptable when having regard for the Australian Standard (AS2890.2-2018), noting that waste collection will be classified as 'occasional service' based on the definitions presented in Section 1.4 of AS2890.2-2018.

Furthermore, future residents of the site will be familiar with the waste collection arrangements, so this is not expected to create any conflicts between vehicles within the site.

For reference, the abovementioned swept path assessment is provided within Appendix D of this report.

### Childcare Centre

Loading and waste collection arrangements for the childcare centre will be consistent with the approved Planning Permit for the site (Permit No. P135/22).

As outlined in the permit documentation, loading activities - primarily undertaken by vans - are expected to occur outside of peak times within available on-site car spaces.

Waste collection will be managed on-site by a private contractor, with vehicle access and manoeuvrability confirmed via the supporting swept path assessment.

### **7.3. Adequacy of Loading and Waste Collection Arrangements**

Based on the above, the waste collection and loading arrangements are considered to be acceptable.

# 8. Traffic Assessment

## 8.1. Traffic Generation

### Residential Village

As outlined in Section 1.2 of this report, a further assessment has been undertaken to confirm the anticipated traffic generation rate, as requested by DTP.

The following section includes the original assessment plus an additional assessment with reference to the existing 'Lifestyle Village' in Bittern.

### Original Assessment

The anticipated traffic generation for the residential village has been adopted based on the average peak hour traffic generation from retirement village case studies.

While this proposal is not a 'retirement' village, it is for 'over 55s' who are typically either retired or working part time. As such, the retirement village case studies are considered most relevant in comparison to regular residential uses.

The AM Peak Hour was estimated based on the average of 4 retirement villages across Victoria, while the PM peak also was based on the above villages plus an additional village in Cranbourne West and 8 other retirement villages across NSW. The case studies are outlined in Table 8.1.

Table 8.1: Case Study Traffic Generation Rates

Village	AM Peak	PM Peak
Rylands, Brighton VIC	0.28	0.24
Templestowe Orchards Retirement Village, Templestowe VIC	0.15	0.18
Mingarra Retirement Village, Croydon VIC	0.18	0.35
Hunters Green Retirement Village, Cranbourne West VIC	-	0.21
Burwood Terrace, Burwood East VIC	0.25	0.19
Retirement Village, Dee Why NSW	-	0.36
Retirement Village, Allambie Heights NSW	-	0.06
Retirement Village, Preston NSW	-	0.17
Retirement Village, Bonnells Bay NSW	-	0.23
Retirement Village, Wamberal NSW	-	0.31

Retirement Village, Kincumber NSW	-	0.23
Retirement Village, Tahmoor NSW	-	0.03
Retirement Village, Bowral NSW	-	0.33
<b>Average</b>	<b>0.22</b>	<b>0.23</b>

A further sanity check on data presented in Table 8.1 has been undertaken with guidance sourced from the land use trip generation information within the Transport for New South Wales “*Guide to Transport Impact Assessment*” document. In this respect, surveys indicate a PM peak hour traffic generation for housing for seniors of 0.23 trips per dwelling for regional areas. This is consistent with the expected PM peak hour traffic generation provided above and is therefore considered fit-for-purpose.

As outlined in Table 8.1 and the sanity check above, the average peak hour traffic generation rates at these sites are as follows:

- **AM Peak Hour:** 0.22 vehicle movements / occupied unit.
- **PM Peak Hour:** 0.23 vehicle movements / occupied unit.

These rates are notably lower than typical residential dwelling traffic generation rates, as the occupants of retirement living / over 50’s villages are most often retired and therefore do not need to be commuting to/from work during the road network peak hours and do not generate the demand for the same number of daily trips.

In addition, the abovementioned surveys indicate a directional split of traffic generation (i.e., the ratio between the inbound and outbound movements) of 45:55 during the AM peak hour and 70:30 during the PM peak hour. Furthermore, peak hour periods typically represent 10% of daily traffic trips.

### Further Assessment – Bittern Lifestyle Village

A case study was undertaken by Traffix Group (dated 3 March 2020 – prior to the first lockdown during the COVID pandemic, which began on the 31 March 2020) of the Lifestyle Village at 17 Booker Rise in Bittern.

The Bittern Lifestyle Village comprised 202 occupied dwellings at the time and had a single vehicle access point to Frankston-Flinders Road. While the Bittern Train Station is located within 500m of the site, it provides access to other townships and day-to-day trips associated with the Village are expected to be undertaken by car.

Traffix Group commissioned 7-day tube count surveys from the 5 February-12 February 2020 of the site access. An analysis of the data revealed:

- AM commuter peak of 0.22 vehicle trips per occupied dwelling.
- PM commuter peak of 0.22 vehicle trips per occupied dwelling.
- A site peak of 0.34 vehicle trips per dwelling at 10:00am – 11:00am.

These rates align with the anticipated traffic generation rates during the commuter peaks of the original assessment.

The full case study prepared by Traffix Group is attached as Appendix E.

## Anticipated Traffic Generation

Applying the preceding assumptions to the proposed 177 units associated with the proposal result in the following traffic movements.

**Table 8.2: Projected Traffic Generation – Residential Village**

	<b>AM Peak</b>	<b>PM Peak</b>
Arriving Trips	18 trips	29 trips
Departing Trips	21 trips	12 trips
<b>Total Trips</b>	<b>39 trips</b>	<b>41 trips</b>

Given the robustness of the above traffic generation assessment from multiple data sources, the traffic generation shown in Table 8.2 is considered accurate of expected traffic demands for this component of the proposed development.

## Childcare Centre

The Transport for New South Wales “*Guide to Transport Impact Assessment*” provides direction on peak hour traffic generation for childcare centres based on survey data from numerous established sites.

The TfNSW Guide includes site peak hour vehicle trip rates for childcare centres. The traffic rates identified include:

- **Site AM Peak Hour** – 0.77 vehicle trips per child.
- **Site PM Peak Hour** – 0.78 vehicle trips per child.

Accordingly, the proposed 164-place childcare centre is anticipated to generate approximately 126 vehicle movements during the AM peak hour period and 128 vehicle movements during the PM peak hour period.

The anticipated traffic generation associated with the childcare centre aspect of the proposal is summarised in Table 8.3.

**Table 8.3: Projected Traffic Generation – Childcare Centre**

	<b>AM Peak</b>	<b>PM Peak</b>
Arriving Trips	63 trips	64 trips
Departing Trips	63 trips	64 trips
<b>Total Trips</b>	<b>126 trips</b>	<b>128 trips</b>

The total traffic generation of the development is summarised in

Table 8.4.

Table 8.4: Total Projected Traffic Generation

	AM Peak	PM Peak
Arriving Trips	81 trips	93 trips
Departing Trips	84 trips	76 trips
<b>Total Trips</b>	<b>165 trips</b>	<b>169 trips</b>

## 8.2. Traffic Distribution

The proposed 177 residential village lots and 164 place childcare centre are anticipated to generate 165 vehicle movements during the AM and 169 vehicle movements during the PM peak hour.

Access to the wider road network will be provided via new connections to Stock Route along the eastern boundary.

As part of the application process for the approved Planning Permit (Permit No. P135/22), the planned closure of Stock Route at its intersection with Maroondah Highway was confirmed by the Department of Transport and Planning (DTP).

In response to the planned closure, all site-generated traffic is proposed to access the broader road network via the north to/from the unsignalised Stock Route / Dead Horse Lane intersection. From this point, traffic is expected to be distributed approximately 60% to the east and 40% to the west, generally reflecting existing travel patterns in the area.

The resulting traffic distribution, which accounts for the planned road closures, is illustrated in Figure 8.1.

Figure 8.1: Traffic Distribution



## 8.3. Post Development Traffic Volumes

The proposed 27 residential lots associated with Stages 4 and 4a of the neighbouring development are anticipated to generate 27 vehicle movements during both the AM and PM peak hours. These trips have been distributed as per the development traffic.

The resultant anticipated post development peak hour traffic volumes including the neighbouring development across the wider road network are shown in Figure 8.2.

Figure 8.2: Post Development Traffic Volumes

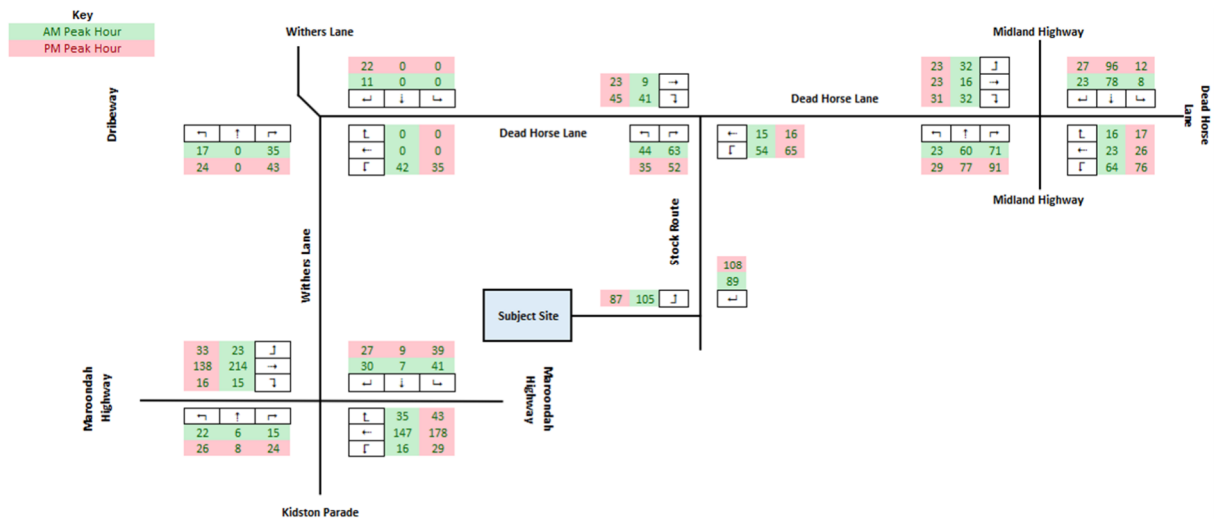

## 8.4. Intersection Analysis

### General

A future conditions peak hour intersection analysis has been undertaken of the following intersections, using the analysis program SIDRA Intersection:

- Stock Route / Dead Horse Lane intersection.
- Withers Lane / Dead Horse Lane intersection.
- Withers Lane / Maroondah Highway intersection.
- Dead Horse Lane / Midland Highway intersection.

### Stock Route / Dead Horse Lane

Having regard to the above, the results for the post development peak hour intersection analysis for the Stock Route / Maroondah Highway intersection are summarised in Table 8.5, with full results provided as Appendix F of this report.

Table 8.5: Post Development Peak SIDRA – Stock Route / Dead Horse Lane Intersection

Approach	Movement	AM Peak Hour			PM Peak Hour		
		DoS	95%ile Queue (m)	Average Delay (s)	DoS	95%ile Queue	Average Delay (s)
Stock Route	Left	0.09	2	6	0.07	2	6
	Right	0.09	2	6	0.07	2	6
Dead Horse Lane (E)	Left	0.04	0	6	0.05	0	6
	Through	0.04	0	0	0.05	0	0
	Through	0.03	1	1	0.04	1	1

Dead Horse	Right	0.03	1	6	0.04	1	6
<b>Intersection</b>		<b>0.09</b>			<b>0.07</b>		

Based on the above, the Stock Route / Dead Horse Lane intersection is expected to continue to operate within 'Excellent' conditions in the AM and PM peak hour, with minimal queues and delays projected.

The preceding analysis indicates that the proposed development will have a negligible impact on the operation of the Stock Route / Dead Horse Lane intersection.

**Withers Lane / Dead Horse Lane**

Having regard to the above, the results for the post development peak hour intersection analysis for the Withers Lane / Dead Horse Lane intersection are summarised in Table 8.6, with full results provided as Appendix F.

**Table 8.6: Post Development Peak SIDRA - Withers Lane / Dead Horse Lane Intersection**

Approach	Movement	AM Peak Hour			PM Peak Hour		
		DoS	95%ile Queue (m)	Average Delay (s)	DoS	95%ile Queue (m)	Average Delay (s)
Withers Lane (S)	Left	0.03	1	5	0.04	1	5
	Right	0.03	1	6	0.04	1	6
Dead Horse Lane	Left	0.03	0	6	0.02	0	6
	Right	0.03	0	5	0.02	0	5
Withers Lane (N)	Left	0.01	1	5	0.02	1	6
	Right	0.01	1	5	0.02	1	5
<b>Intersection</b>		<b>0.03</b>			<b>0.04</b>		

Based on the above, the Withers Lane / Dead Horse Lane intersection is expected to continue to operate within 'Excellent' conditions in the AM and PM peak hour, with minimal queues and delays projected.

The preceding analysis indicates that the proposed development will have a negligible impact on the operation of the Withers Lane / Dead Horse Lane intersection.

**Withers Lane / Maroondah Highway**

Having regard to the above, the results for the post development peak hour intersection analysis for the Withers Lane / Maroondah Highway intersection are summarised Table 8.7, with full results provided as Appendix E.

Accordingly, the following SIDRA analysis has considered the Withers Lane / Maroondah Highway intersection in post upgrade conditions.

Table 8.7: Post Development Peak SIDRA – Withers Lane / Maroondah Highway Intersection

Approach	Movement	AM Peak Hour			PM Peak Hour		
		DoS	95%ile Queue (m)	Average Delay (s)	DoS	95%ile Queue (m)	Average Delay (s)
Kidston Parade	Left	0.10	2	8	0.13	3	9
	Through	0.10	2	15	0.13	3	15
	Right	0.10	2	17	0.13	3	17
Maroondah Highway (E)	Left	0.01	0	7	0.02	0	7
	Through	0.08	0	0	0.09	0	0
	Right	0.03	1	8	0.04	1	7
Withers Lane	Left	0.17	4	9	0.16	4	8
	Through	0.17	4	16	0.16	4	15
	Right	0.17	4	17	0.16	4	16
Maroondah Highway (W)	Left	0.01	0	7	0.02	0	7
	Through	0.12	0	0	0.08	0	0
	Right	0.01	0	7	0.02	0	8
<b>Intersection</b>		<b>0.17</b>			<b>0.16</b>		

Based on the above, the Withers Lane / Maroondah Highway intersection is expected to operate within 'Excellent' conditions in the AM and PM peak hour, with minimal queues and delays projected.

The preceding analysis indicates that the proposed development will have a negligible impact on the operation of the Withers Lane / Maroondah Highway intersection.

### Dead Horse Lane / Midland Highway

Having regard to the above, the results for the post development peak hour intersection analysis for the Dead Horse Lane / Midland Highway intersection are summarised in Table 8.8, with full results provided as Appendix F.

Table 8.8: Post Development Peak SIDRA – Dead Horse Lane / Midland Highway

Approach	Movement	AM Peak Hour			PM Peak Hour		
		DoS	95%ile Queue (m)	Average Delay (s)	DoS	95%ile Queue (m)	Average Delay (s)
Midland Highway (S)	Left	0.09	3	7	0.12	4	7
	Through	0.09	3	0	0.12	4	1

	Right	0.09	3	7	0.12	4	7
Dead Horse Lane (E)	Left	0.09	3	6	0.11	3	6
	Through	0.09	3	5	0.11	3	6
	Right	0.09	3	7	0.11	3	8
Midland Highway (N)	Left	0.06	1	7	0.08	1	7
	Through	0.06	1	0	0.08	1	0
	Right	0.06	1	7	0.08	1	7
Dead Horse Lane (W)	Left	0.08	2	6	0.09	2	6
	Through	0.08	2	5	0.09	2	6
	Right	0.08	2	8	0.09	2	8
<b>Intersection</b>		<b>0.09</b>			<b>0.12</b>		

Based on the above, the Dead Horse Lane / Midland Highway intersection is expected to operate within 'Excellent' conditions in the AM and PM peak hour, with minimal queues and delays projected.

The preceding analysis indicates that the proposed development will have a negligible impact on the operation of Dead Horse Lane / Midland Highway intersection.

## 8.5. Highway Intersections - 10-Year Post Development Assessment

As per the request from DTP, a 10-year post development assessment has been undertaken of the following intersections:

- Withers Lane / Maroondah Highway
- Dead Horse Lane / Midland Highway.

As per Section 2.4 of this report, an accumulative growth rate of 2% per year has been applied to the through volumes on Maroondah Highway and Midland Highway for 10 years. The resulting traffic volumes are presented in Figure 8.3.

Figure 8.3: 10 Year Post Development Traffic Volumes

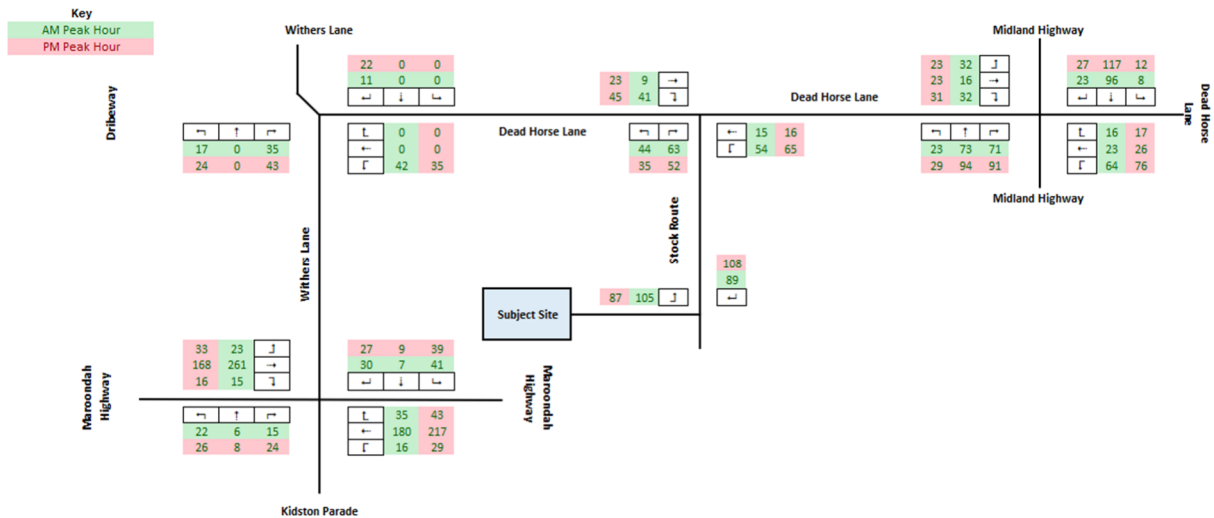

A SIDRA analysis of the 10-year post development scenario for Withers Lane / Maroondah Highway and Dead Horse Lane / Midland Highway were undertaken and are presented in Table 8.9 and Table 8.10, with detailed results provided in Appendix G of this report.

Table 8.9: 10 Year Post Development Peak SIDRA - Withers Lane / Maroondah Highway

Approach	Movement	AM Peak Hour			PM Peak Hour		
		DoS	95%ile Queue (m)	Average Delay (s)	DoS	95%ile Queue (m)	Average Delay (s)
Kidston Parade	Left	0.11	3	9	0.15	4	9
	Through	0.11	3	18	0.15	4	17
	Right	0.11	3	20	0.15	4	19
Maroondah Highway (E)	Left	0.01	0	7	0.02	0	7
	Through	0.10	0	0	0.12	0	0
	Right	0.04	1	8	0.04	1	8
Withers Lane	Left	0.20	5	9	0.18	5	9
	Through	0.20	5	18	0.18	5	17
	Right	0.20	5	20	0.18	5	19
Maroondah Highway (W)	Left	0.01	0	7	0.02	0	7
	Through	0.14	0	0	0.09	0	0
	Right	0.01	0	7	0.02	0	8
<b>Intersection</b>		<b>0.20</b>			<b>0.18</b>		

Table 8.10: 10 Year Post Development Peak SIDRA - Dead Horse Lane / Midland Highway

Approach	Movement	AM Peak Hour			PM Peak Hour		
		DoS	95%ile Queue (m)	Average Delay (s)	DoS	95%ile Queue (m)	Average Delay (s)
Midland Highway (S)	Left	0.10	3	7	0.13	4	7
	Through	0.10	3	0	0.13	4	1
	Right	0.10	3	7	0.13	4	7
Dead Horse Lane (E)	Left	0.09	3	6	0.11	3	6
	Through	0.09	3	6	0.11	3	6
	Right	0.09	3	7	0.11	3	8
Midland Highway (N)	Left	0.07	1	7	0.09	2	7
	Through	0.07	1	0	0.09	2	0
	Right	0.07	1	7	0.09	2	7
Dead Horse Lane (W)	Left	0.09	2	6	0.09	2	6
	Through	0.09	2	5	0.09	2	6
	Right	0.09	2	8	0.09	2	8
<b>Intersection</b>		<b>0.10</b>			<b>0.13</b>		

The 10 years of growth applied to Maroondah Highway and Midland Highway have had a negligible impact on the operation of both intersections assessed, with both continuing to operate under 'excellent' conditions in the 10-year assessment scenario.

### Intersection Operation Summary

The proposed access arrangements from the subject site to the adjacent local road network are considered appropriate, noting that all intersections surrounding the site will continue to operate well under their theoretical capacity.

Having regard to the above analysis and discussion, against the existing traffic volumes in the vicinity of the site, the additional traffic generated by the proposed development could not be expected to compromise the safety and function of the surrounding road network.

## 8.6. Turn Warrant Treatments

While there are channelised turn lanes to Withers Lane on Maroondah Highway, there are currently no turn treatments to Dead Horse Lane from Midland Highway.

The warrants for turn treatments are detailed in Section 3.3.6 of Austroads Guide to Traffic Management (AGTM) Part 6.

To determine the warranted turn treatments, the peak hour turning movements ( $Q_R$  and  $Q_L$ ) and the relevant major road traffic volume ( $Q_M$ ) for each turn treatment is required.

Calculating the  $Q_M$  is outlined in Figure 3.26 of AGTM Part 6, this figure is reproduced as Figure 8.4.

Figure 8.4: Calculation for Major Road Traffic Volume

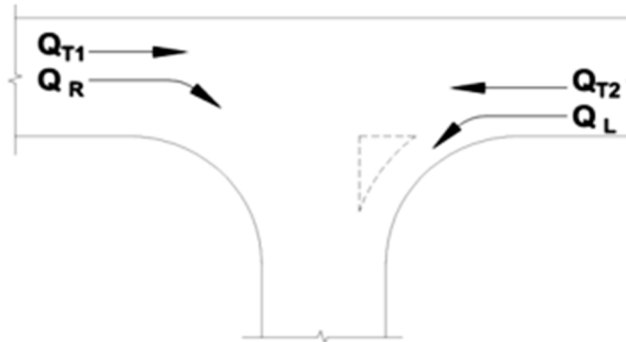

Road type	Turn type	Splitter island	$Q_M$ (veh/h)
Two-lane two-way	Right	No	$= Q_{T1} + Q_{T2} + Q_L$
		Yes	$= Q_{T1} + Q_{T2}$
	Left	Yes or no	$= Q_{T2}$

Source: Austroads Guide to Traffic Management – Part 6

Application of the above to the critical peak (which is the PM peak in this instance) for Dead Horse Lane / Midland Highway results in the following applicable traffic volumes:

**Existing scenario**

- Left turn treatment:  $Q_M$ : 77 vph,  $Q_L$ : 3 vph.
- Right turn treatment:  $Q_M$ : 176 vph,  $Q_R$ : 1 vph.

**10-year post development scenario**

- Left turn treatment:  $Q_M$ : 94 vph,  $Q_L$ : 29 vph.
- Right turn treatment:  $Q_M$ : 240 vph,  $Q_R$ : 27 vph.

The above volumes were placed on the turn treatments warrants graphic provided in AGTM Part 6, as shown in Figure 8.5.

Figure 8.5: Warrants for turn treatments - Dead Horse Lane / Midland Highway

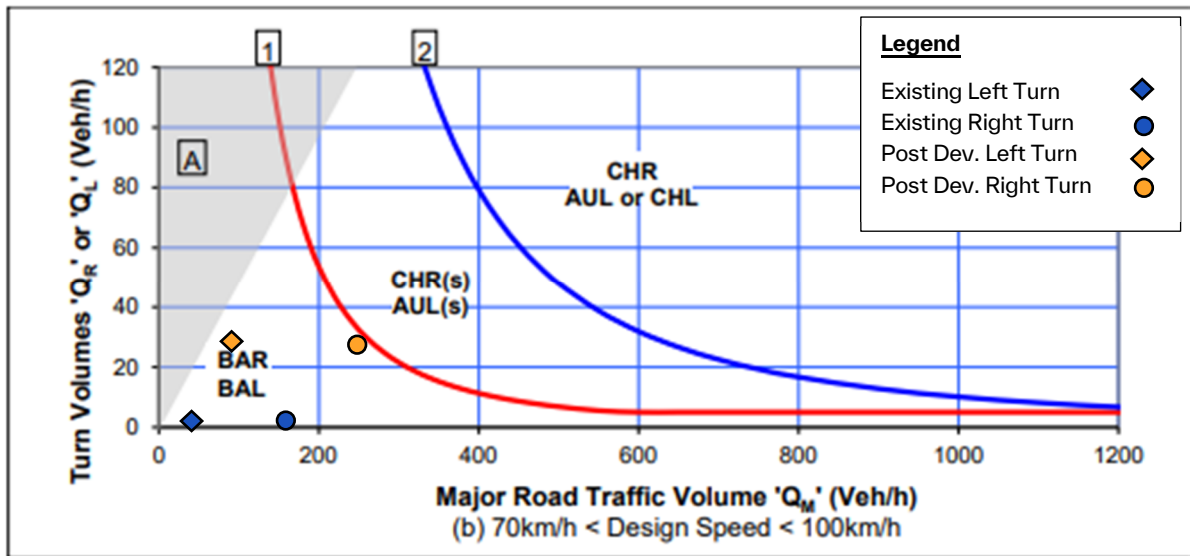

Source: Austroads Guide to Traffic Management - Part 6

Both the existing and 10-year post development traffic volumes warrant basic turn lanes for both the left and right turn into Dead Horse Lane from Midland Highway.

As such, the proposed development does not trigger a higher-order turn treatment than the existing scenario.

Neighbouring vacant properties are zoned as neighbourhood/residential. The development of the wider area may warrant higher-order turn treatments for any future application of neighbouring land.

# 9. Conclusion

Based on the analysis and discussion presented within this report, the following conclusions are made:

- The proposed development generates a statutory car parking requirement of 249-426 car parking spaces.
- On-site car parking will be provided either in accordance with or exceed the statutory requirements and is considered appropriate to support the proposed development.
- The proposed access arrangements, car/bicycle parking layout have been designed in accordance with the dimensional requirements of Clause 52.06 of the Mansfield Shire Planning Scheme and/or the relevant sections of the Australian Standard AS2890 series.
- CAD-based swept paths have been completed which confirm the key vehicle movements can be completed with adequate clearance through the site access point and relevant key areas within the site.
- The proposed development does not trigger a statutory requirement for bicycle parking provision.
- The proposed 177 residential village lots and 164 place childcare centre are anticipated to generate 165 vehicle movements during the AM and 169 vehicle movements during the PM peak hour. Traffic generation rates supported by case study of the Bittern Lifestyle Village.
- The level of traffic generated by the proposed development can be accommodated by the adjacent road network without creating adverse impacts.
- An assessment of the warrants for turn treatments for the Dead Horse Lane / Midland Highway intersection revealed both the existing and 10-year post development scenario will result in requirements for basic turn treatments. As such, the proposed development does not change the warranted turn treatments.
- It should also be noted that the anticipated future development of the neighbouring sites may require future turn treatment requirements, which would need to be assessed independently at a future point in time that neighbouring parcels are developed.

Overall, based on the assessments undertaken, the proposed development is considered to be acceptable from a transport engineering perspective and is not expected to create adverse traffic or parking impacts in the area.

# Appendix A - Development Plans

50 x 80 = 4000sqm

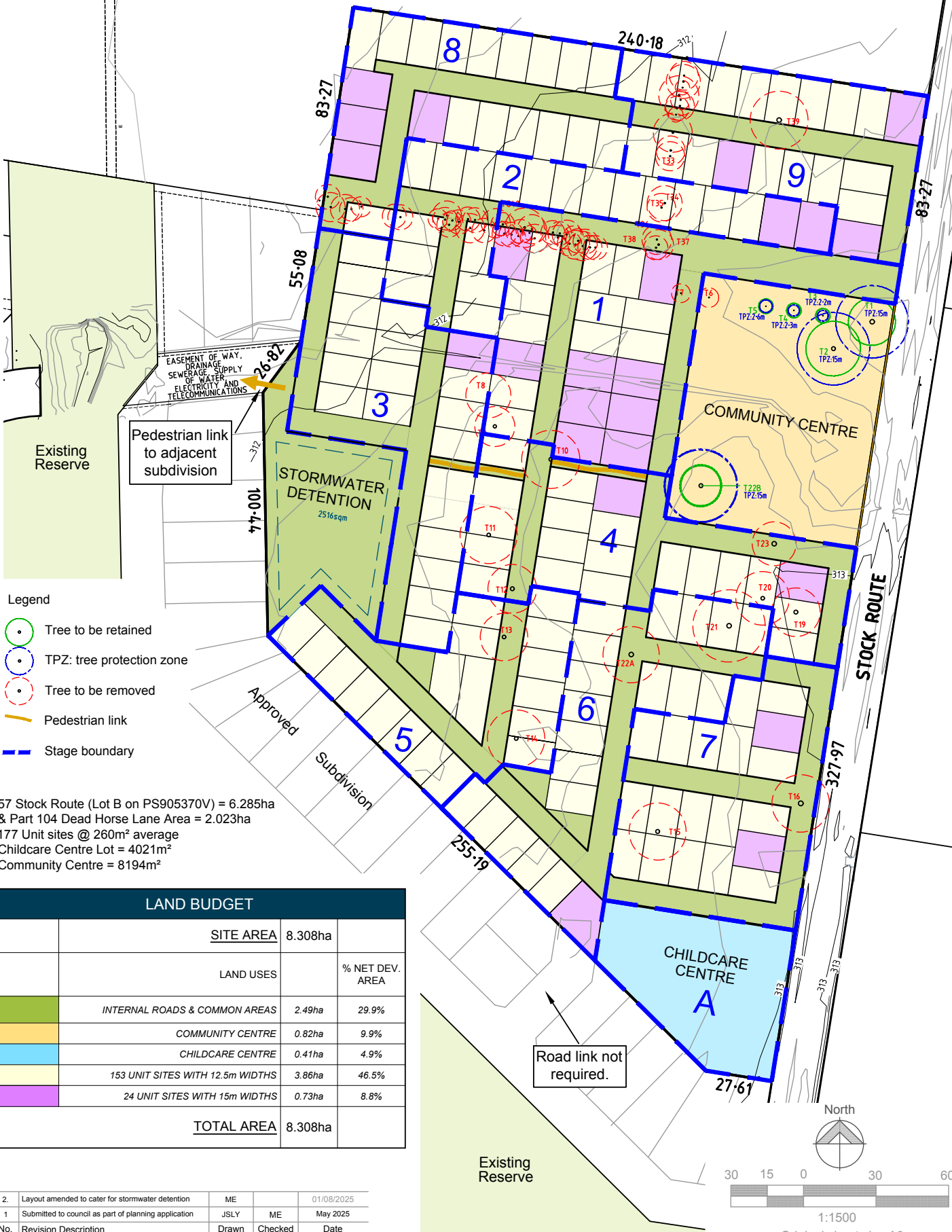

**Legend**

- Tree to be retained
- TPZ: tree protection zone
- Tree to be removed
- Pedestrian link
- Stage boundary

57 Stock Route (Lot B on PS905370V) = 6.285ha  
 & Part 104 Dead Horse Lane Area = 2.023ha  
 177 Unit sites @ 260m<sup>2</sup> average  
 Childcare Centre Lot = 4021m<sup>2</sup>  
 Community Centre = 8194m<sup>2</sup>

LAND BUDGET			
	<b>SITE AREA</b>	8.308ha	
	<b>LAND USES</b>		<b>% NET DEV. AREA</b>
	INTERNAL ROADS & COMMON AREAS	2.49ha	29.9%
	COMMUNITY CENTRE	0.82ha	9.9%
	CHILDCARE CENTRE	0.41ha	4.9%
	153 UNIT SITES WITH 12.5m WIDTHS	3.86ha	46.5%
	24 UNIT SITES WITH 15m WIDTHS	0.73ha	8.8%
	<b>TOTAL AREA</b>	8.308ha	

2.	Layout amended to cater for stormwater detention	ME		01/08/2025
1	Submitted to council as part of planning application	JSLY	ME	May 2025
No.	Revision Description	Drawn	Checked	Date

Road link not required.

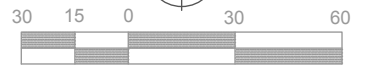

Millar & Merrigan authorize the use of this drawing only for the purpose described by the status stamp shown below. This drawing should be read in conjunction with all relevant contracts, specifications, reports & drawings.  
 © Millar & Merrigan Pty. Ltd.

**Millar Merrigan**  
 Land Development Consultants

Millar & Merrigan Pty Ltd | ACN 005 541 668  
 Croydon 2/126 Merrindale Drive, Croydon VIC 3136  
 Morwell 156 Commercial Road, Morwell VIC 3840  
 Yarrowonga 91 Belmore Street, Yarrowonga VIC 3730  
 mail@millarmerrigan.com.au | millarmerrigan.com.au  
 (03) 8720 9500 | SAI GLOBAL Quality ISO 9001

Civil Engineering  
 Land Surveying  
 Asset Recording  
 Landscape Architecture  
 Project Management  
 Town Planning  
 Building Design  
 Structural Engineering

**MASTER PLAN**  
 PROPOSED LIFESTYLE VILLAGE  
 57 Stock Route Road, Mansfield &  
 Part 104 Dead Horse Lane, Mansfield  
 Mansfield Shire Council  
**32495P3**  
 Version 2  
 Sheet 1 of 1

**FOR APPROVAL**

# Appendix B – Traffic Survey Data

## Intersection of Dead Horse Ln and Stock Route, Mansfield

GPS -37.042153, 146.080653

Date:	Tue 28/03/23
Weather:	Overcast
Suburban:	Mansfield
Customer:	Ratio

North:	N/A
East:	Dead Horse Ln
South:	Stock Route
West:	Dead Horse Ln

Survey Period	AM:	7:00 AM-10:00 AM
	PM:	3:00 PM-6:00 PM
Traffic Peak	AM:	8:15 AM-9:15 AM
	PM:	3:00 PM-4:00 PM

### All Vehicles

Time		East Approach Dead Horse Ln			South Approach Stock Route			West Approach Dead Horse Ln			Hourly Total	
Period Start	Period End	U	WB	L	U	R	L	U	R	EB	Hour	Peak
7:00	7:15	0	1	0	0	0	0	0	0	2	20	
7:15	7:30	0	1	0	0	0	0	0	0	1	25	
7:30	7:45	0	3	0	0	0	0	0	1	1	29	
7:45	8:00	0	5	0	0	0	0	0	0	5	32	
8:00	8:15	0	0	0	0	0	0	0	0	8	32	
8:15	8:30	0	2	0	0	0	0	0	2	2	33	Peak
8:30	8:45	0	4	1	0	0	1	0	2	0	33	Peak
8:45	9:00	0	4	0	0	0	0	0	2	4	29	
9:00	9:15	0	5	0	0	0	1	0	0	3	32	
9:15	9:30	0	5	0	0	0	0	0	0	1		
9:30	9:45	0	1	0	0	0	0	0	0	3		
9:45	10:00	0	7	0	0	0	0	0	1	5		
15:00	15:15	0	5	0	0	0	0	0	0	5	43	Peak
15:15	15:30	0	5	0	0	0	0	0	0	6	42	
15:30	15:45	0	5	0	0	0	0	0	1	4	42	
15:45	16:00	0	3	0	0	0	0	0	1	8	43	Peak
16:00	16:15	0	3	2	0	0	0	0	0	4	40	
16:15	16:30	0	5	0	0	0	0	0	0	6	36	
16:30	16:45	0	4	0	0	0	0	0	0	7	39	
16:45	17:00	0	4	0	0	0	0	0	0	5	34	
17:00	17:15	0	3	0	0	0	0	0	0	2	36	
17:15	17:30	0	5	0	0	0	0	0	0	9		
17:30	17:45	0	0	0	0	1	0	0	1	4		
17:45	18:00	0	6	0	0	0	0	0	2	3		

Peak Time		East Approach Dead Horse Ln			South Approach Stock Route			West Approach Dead Horse Ln			Peak total
Period Start	Period End	U	WB	L	U	R	L	U	R	EB	
8:15	9:15	0	15	1	0	0	2	0	6	9	33
15:00	16:00	0	18	0	0	0	0	0	2	23	43

Note: Site sketch is for illustrating traffic flows. Direction is indicative only, drawing is not to scale and not an exact streets configuration.

### Graphic

Total
Light
Heavy

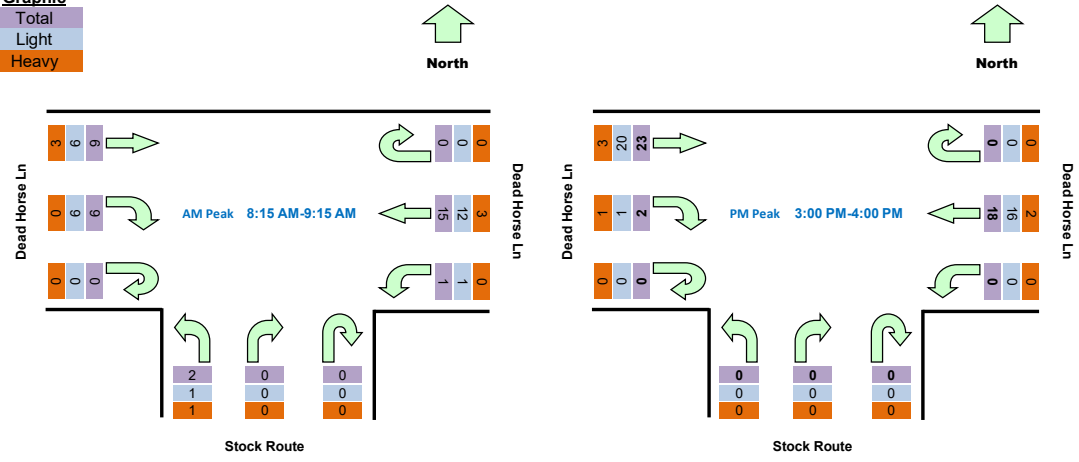

# TRANS TRAFFIC SURVEY

## TURNING MOVEMENT SURVEY

trafficsurvey.com.au



### Intersection of Dead Horse Ln and Withers Ln, Mansfield

The intersection has been rebuilt, see the image from the camera

GPS: -37.041254, 146.073684

Date:	Tue 28/03/23
Weather:	Overcast
Suburban:	Mansfield
Customer:	Ratio

North:	Withers Ln
East:	Dead Horse Ln
South:	Withers Ln
West:	Driveway

Survey Period	AM: 7:00 AM-10:00 AM
	PM: 3:00 PM-6:00 PM
Traffic Peak	AM: 7:45 AM-8:45 AM
	PM: 3:15 PM-4:15 PM

All Vehicles

Time		North Approach Withers Ln				East Approach Dead Horse Ln				South Approach Withers Ln				West Approach Driveway				Hourly Total	
Period Start	Period End	U	R	SB	L	U	R	WB	L	U	R	NB	L	U	R	EB	L	Hour	Peak
7:00	7:15	0	0	3	0	0	0	0	0	0	0	3	0	0	0	0	0	19	
7:15	7:30	0	0	0	0	0	0	0	0	0	0	1	1	0	0	0	0	23	
7:30	7:45	0	0	1	0	0	0	0	0	0	0	0	0	0	1	0	0	27	
7:45	8:00	0	0	3	0	0	0	0	0	0	0	6	0	0	0	0	0	29	Peak
8:00	8:15	0	0	2	0	0	0	0	0	0	0	8	0	0	0	0	0	29	Peak
8:15	8:30	0	0	2	0	0	0	0	0	0	0	3	0	0	0	0	1	24	
8:30	8:45	0	0	4	0	0	0	0	0	0	0	0	0	0	0	0	0	25	
8:45	9:00	0	0	5	0	0	0	0	0	0	0	4	0	0	0	0	0	24	
9:00	9:15	0	0	3	0	0	0	0	0	0	0	1	1	0	0	0	0	26	
9:15	9:30	0	2	4	0	0	0	0	0	0	0	1	0	0	0	0	0		
9:30	9:45	0	0	1	0	0	0	0	0	0	0	1	0	0	0	0	1		
9:45	10:00	0	0	4	0	0	0	0	0	0	0	7	0	0	0	0	0		
15:00	15:15	0	0	3	0	0	0	0	0	0	0	1	1	0	0	0	1	43	
15:15	15:30	0	0	6	0	0	0	0	0	0	0	6	1	0	1	0	0	46	Peak
15:30	15:45	0	0	6	0	0	0	0	0	0	0	4	1	0	1	0	0	43	
15:45	16:00	0	0	3	0	0	0	0	0	0	0	8	0	0	0	0	0	40	
16:00	16:15	0	0	4	0	0	0	0	0	0	0	4	0	0	1	0	0	38	
16:15	16:30	0	0	4	0	0	0	0	0	0	0	6	0	0	1	0	0	39	
16:30	16:45	1	0	3	0	0	0	0	0	0	0	4	0	0	1	0	0	38	
16:45	17:00	0	0	4	0	0	0	0	0	0	0	5	0	0	0	0	0	33	
17:00	17:15	0	0	7	0	0	0	0	0	0	0	2	0	0	1	0	0	31	
17:15	17:30	0	0	4	0	0	0	0	0	0	0	5	0	0	1	0	0		
17:30	17:45	0	0	0	0	0	0	0	0	0	0	2	0	0	0	0	2		
17:45	18:00	0	0	5	0	0	0	0	0	0	0	1	1	0	0	0	0		

Peak Time		North Approach Withers Ln				East Approach Dead Horse Ln				South Approach Withers Ln				West Approach Driveway				Peak total
Period Start	Period End	U	R	SB	L	U	R	WB	L	U	R	NB	L	U	R	EB	L	
7:45	8:45	0	0	11	0	0	0	0	0	0	0	17	0	0	0	0	1	29
15:15	16:15	0	0	19	0	0	0	0	0	0	0	22	2	0	3	0	0	46

Note: Site sketch is for illustrating traffic flows. Direction is indicative only, drawing is not to scale and not an exact streets configuration.

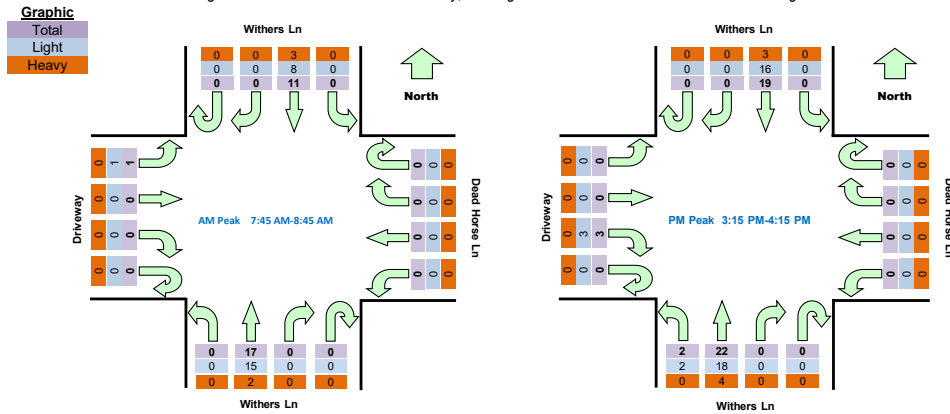

## Intersection of Maroondah Hwy and Withers Ln, Mansfield

GPS -37.049951, 146.071847

Date:	Tue 28/03/23
Weather:	Overcast
Suburban:	Mansfield
Customer:	Ratio

North:	Withers Ln
East:	Maroondah Hwy
South:	Withers Ln
West:	Maroondah Hwy

Survey Period	AM: 7:00 AM-10:00 AM
	PM: 3:00 PM-6:00 PM
Traffic Peak	AM: 8:15 AM-9:15 AM
	PM: 3:30 PM-4:30 PM

### All Vehicles

Time		North Approach Withers Ln				East Approach Maroondah Hwy				South Approach Withers Ln				West Approach Maroondah Hwy				Hourly Total	Peak
Period Start	Period End	U	R	SB	L	U	R	WB	L	U	R	NB	L	U	R	EB	L	Hour	Peak
7:00	7:15	0	1	1	2	0	2	23	2	0	2	1	3	0	1	22	1	266	
7:15	7:30	0	2	3	1	0	0	22	6	0	0	1	0	0	1	29	3	282	
7:30	7:45	0	2	1	0	0	2	24	3	0	3	0	5	0	3	24	0	317	
7:45	8:00	0	1	1	1	0	3	18	1	0	3	2	0	0	2	36	2	373	
8:00	8:15	0	1	1	1	0	1	19	3	0	0	4	4	0	7	35	1	442	
8:15	8:30	0	1	3	6	0	1	25	2	0	3	2	6	0	6	47	1	478	Peak
8:30	8:45	0	2	2	6	0	3	43	6	0	4	0	5	0	1	51	0	460	
8:45	9:00	0	4	2	5	0	8	42	6	0	3	2	4	0	5	54	4	419	
9:00	9:15	0	2	0	3	0	5	31	2	0	5	2	7	0	3	53	0	374	
9:15	9:30	0	2	1	2	0	1	23	5	0	8	2	1	0	2	38	0		
9:30	9:45	0	1	1	3	1	1	31	2	0	5	1	3	0	1	32	0		
9:45	10:00	0	3	1	0	0	2	26	11	0	5	4	3	0	1	36	2		
15:00	15:15	0	2	3	1	0	2	28	4	0	5	1	4	0	4	32	2	426	
15:15	15:30	0	0	4	5	0	4	35	5	0	12	2	2	0	2	31	5	470	
15:30	15:45	0	3	2	8	0	6	38	5	0	5	2	8	0	5	24	3	478	Peak
15:45	16:00	0	3	1	3	0	3	41	9	0	7	3	8	0	4	37	3	476	
16:00	16:15	0	1	4	5	0	9	49	9	0	6	2	7	0	2	36	2	454	
16:15	16:30	0	3	2	6	0	3	42	6	0	6	1	3	0	5	35	3	432	
16:30	16:45	0	3	1	2	0	4	51	3	0	3	2	5	0	3	26	4	421	
16:45	17:00	0	2	2	2	0	3	41	4	0	5	3	5	0	1	31	1	396	
17:00	17:15	0	1	5	2	0	7	40	5	0	3	3	6	0	5	31	2	396	
17:15	17:30	0	0	3	4	0	2	37	5	0	3	2	7	0	4	35	2		
17:30	17:45	0	0	1	0	0	4	44	3	0	2	1	8	0	2	17	0		
17:45	18:00	0	2	2	7	0	3	39	9	0	4	2	5	0	2	24	1		

Peak Time		North Approach Withers Ln				East Approach Maroondah Hwy				South Approach Withers Ln				West Approach Maroondah Hwy				Peak total
Period Start	Period End	U	R	SB	L	U	R	WB	L	U	R	NB	L	U	R	EB	L	Peak total
8:15	9:15	0	9	7	20	0	17	141	16	0	15	6	22	0	15	205	5	478
15:30	16:30	0	10	9	22	0	21	170	29	0	24	8	26	0	16	132	11	478

Note: Site sketch is for illustrating traffic flows. Direction is indicative only, drawing is not to scale and not an exact streets configuration.

### Graphic

Total  
Light  
Heavy

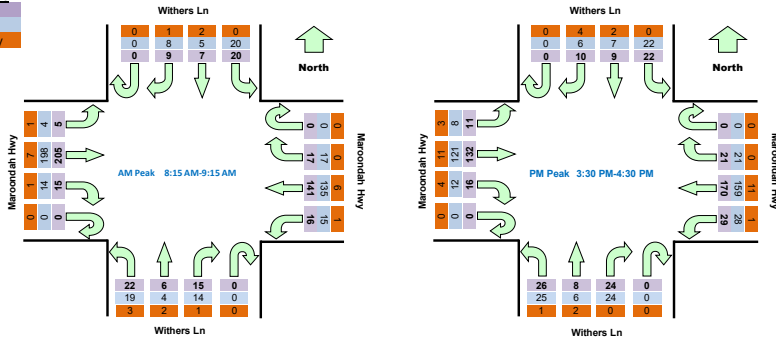

## Intersection of Dead Horse Ln and Midland Hwy, Mansfield

GPS -37.043356, 146.089883

Date:	Tue 28/03/23
Weather:	Overcast
Suburban:	Mansfield
Customer:	Ratio

North:	Midland Hwy
East:	Dead Horse Ln
South:	Midland Hwy
West:	Dead Horse Ln

Survey Period	AM: 7:00 AM-10:00 AM
	PM: 3:00 PM-6:00 PM
Traffic Peak	AM: 8:15 AM-9:15 AM
	PM: 3:30 PM-4:30 PM

All Vehicles

Time	North Approach Midland Hwy	East Approach Dead Horse Ln	South Approach Midland Hwy	West Approach Dead Horse Ln	Hourly Total	Peak													
Period Start	Period End	U	R	SB	L	U	R	WB	L	U	R	NB	L	U	R	EB	L	Hour	Peak
7:00	7:15	0	0	13	4	0	4	1	11	0	13	7	0	0	0	2	1	243	
7:15	7:30	0	0	14	1	0	4	1	8	0	2	15	0	0	0	1	0	243	
7:30	7:45	0	0	10	1	0	5	1	12	0	8	15	1	0	1	1	0	278	
7:45	8:00	0	0	17	3	0	6	3	22	0	10	19	2	0	2	1	1	300	
8:00	8:15	0	0	18	0	0	2	0	9	0	7	12	0	0	1	7	0	310	
8:15	8:30	0	0	23	4	0	2	2	17	0	16	12	1	0	2	0	2	324	Peak
8:30	8:45	0	0	16	2	0	6	4	20	0	11	13	0	0	2	0	3	296	
8:45	9:00	0	1	27	1	0	4	3	16	0	23	17	0	0	2	1	1	267	
9:00	9:15	0	1	9	1	0	4	3	11	0	21	15	1	0	1	2	1	247	
9:15	9:30	0	1	10	3	0	4	4	12	0	5	13	0	0	0	0	1		
9:30	9:45	0	1	14	1	0	3	0	9	0	8	9	0	0	1	1	1		
9:45	10:00	0	0	12	7	0	4	6	17	0	8	16	1	0	1	3	1		
15:00	15:15	0	1	16	2	0	3	4	17	0	20	14	0	0	2	2	0	375	
15:15	15:30	0	2	23	2	0	4	4	32	0	12	11	1	0	2	5	0	396	
15:30	15:45	0	0	15	3	0	8	3	15	0	21	20	1	0	2	5	0	404	Peak
15:45	16:00	0	0	19	2	0	1	6	23	0	26	19	0	0	3	4	0	388	
16:00	16:15	0	0	40	2	0	2	1	21	0	22	10	1	0	1	2	0	375	
16:15	16:30	0	1	18	5	0	6	3	17	0	22	25	1	0	4	2	2	364	
16:30	16:45	0	1	19	2	1	4	3	18	0	12	12	0	0	1	3	1	334	
16:45	17:00	0	1	20	2	0	1	3	19	0	20	15	1	0	1	6	1	308	
17:00	17:15	0	1	18	1	0	2	2	22	0	28	14	1	0	0	2	0	286	
17:15	17:30	0	1	12	2	0	4	2	16	0	12	17	2	0	4	4	0		
17:30	17:45	0	0	16	1	0	1	0	6	0	11	12	0	0	1	3	0		
17:45	18:00	0	1	19	6	0	2	4	7	0	7	18	1	0	1	2	0		

Peak Time	North Approach Midland Hwy	East Approach Dead Horse Ln	South Approach Midland Hwy	West Approach Dead Horse Ln	Peak total														
Period Start	Period End	U	R	SB	L	U	R	WB	L	U	R	NB	L	U	R	EB	L	Hour	Peak
8:15	9:15	0	2	75	8	0	16	12	64	0	71	57	2	0	7	3	7	324	
15:30	16:30	0	1	92	12	0	17	13	76	0	91	74	3	0	10	13	2	404	

Note: Site sketch is for illustrating traffic flows. Direction is indicative only, drawing is not to scale and not an exact streets configuration.

Graphic

Total  
Light  
Heavy

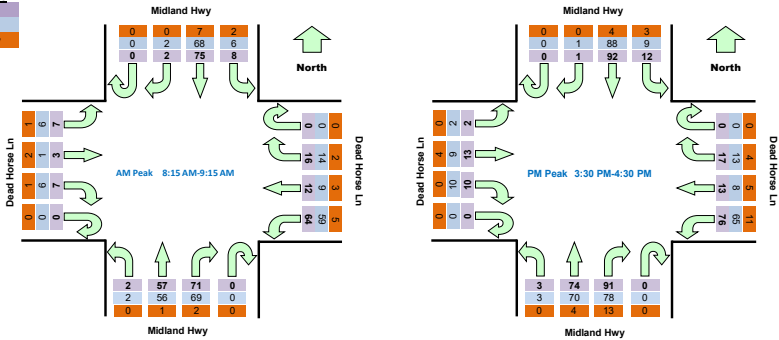

# Appendix C – Existing Conditions SIDRA Results

# MOVEMENT SUMMARY

Site: [101] Dead Horse Lane / Withers Lane / Driveway - Existing - AM Peak (Dead Horse Lane / Withers Lane / Driveway)  
 Output produced by SIDRA INTERSECTION Version: 10.0.4.216

Dead Horse Lane / Withers Lane / Driveway - Existing - AM Peak  
 Site Category: (None)  
 Give-Way (Two-Way)  
 Site Scenario: 1 | Local Volumes

Vehicle Movement Performance															
Mov ID	Turn	Mov Class	Demand Flows		Arrival Flows		Deg. Satn	Aver. Delay	Level of Service	95% Back Of Queue		Prop. Qued	Eff. Stop of Cycles	Number of Cycles to Depart	Aver. Speed
			[ Total HV ]	[ Total HV ]	[ Total HV ]	[ Total HV ]	v/c	sec		[ Veh. ]	[ Dist ]		Rate		km/h
			veh/h	%	veh/h	%				veh	m				
South: Withers Lane (S)															
1	L2	All MCs	1	0.0	1	0.0	0.010	5.5	LOS A	0.0	0.1	0.01	0.06	0.01	56.9
2	T1	All MCs	18	0.0	18	0.0	0.010	0.0	LOS A	0.0	0.1	0.01	0.06	0.01	59.4
3	R2	All MCs	1	0.0	1	0.0	0.010	5.4	LOS A	0.0	0.1	0.01	0.06	0.01	56.6
Approach			20	0.0	20	0.0	0.010	0.6	NA	0.0	0.1	0.01	0.06	0.01	59.1
East: Dead Horse Lane															
4	L2	All MCs	1	0.0	1	0.0	0.002	5.6	LOS A	0.0	0.1	0.07	0.54	0.07	53.1
5	T1	All MCs	1	0.0	1	0.0	0.002	4.2	LOS A	0.0	0.1	0.07	0.54	0.07	53.5
6	R2	All MCs	1	0.0	1	0.0	0.002	5.6	LOS A	0.0	0.1	0.07	0.54	0.07	52.8
Approach			3	0.0	3	0.0	0.002	5.1	LOS A	0.0	0.1	0.07	0.54	0.07	53.1
North: Withers Lane (N)															
7	L2	All MCs	1	0.0	1	0.0	0.007	5.5	LOS A	0.0	0.1	0.02	0.09	0.02	56.7
8	T1	All MCs	12	0.0	12	0.0	0.007	0.0	LOS A	0.0	0.1	0.02	0.09	0.02	59.1
9	R2	All MCs	1	0.0	1	0.0	0.007	5.5	LOS A	0.0	0.1	0.02	0.09	0.02	56.4
Approach			14	0.0	14	0.0	0.007	0.8	NA	0.0	0.1	0.02	0.09	0.02	58.7
West: Local Driveway															
10	L2	All MCs	1	0.0	1	0.0	0.002	5.6	LOS A	0.0	0.1	0.08	0.54	0.08	53.0
11	T1	All MCs	1	0.0	1	0.0	0.002	4.2	LOS A	0.0	0.1	0.08	0.54	0.08	53.4
12	R2	All MCs	1	0.0	1	0.0	0.002	5.6	LOS A	0.0	0.1	0.08	0.54	0.08	52.7
Approach			3	0.0	3	0.0	0.002	5.1	LOS A	0.0	0.1	0.08	0.54	0.08	53.1
All Vehicles			40	0.0	40	0.0	0.010	1.4	NA	0.0	0.1	0.02	0.15	0.02	57.9

Site Level of Service (LOS) Method: Delay (SIDRA). Site LOS Method is specified in the Parameter Settings dialog (Options tab).  
 Vehicle movement LOS values are based on average delay per movement.  
 Minor Road Approach LOS values are based on average delay for all vehicle movements.  
 NA (TWSC): Level of Service is not defined for major road approaches or the intersection as a whole for Two-Way Sign Control (HCM LOS rule).  
 Two-Way Sign Control Capacity Model: SIDRA Standard.  
 Delay Model: SIDRA Standard (Control Delay: Geometric Delay is included).  
 Queue Model: SIDRA queue estimation methods are used for Back of Queue and Queue at Start of Gap.  
 Gap-Acceptance Capacity Formula: SIDRA Standard (Akçelik M3D).  
 HV (%) values are calculated for All Movement Classes of All Heavy Vehicle Model Designation.  
 Arrival Flows used in performance calculations are adjusted to include any Initial Queued Demand and Upstream Capacity Constraint effects.

# MOVEMENT SUMMARY

Site: [104] Dead Horse Lane / Withers Lane / Driveway - Existing - PM Peak (Dead Horse Lane / Withers Lane / Driveway)  
 Output produced by SIDRA INTERSECTION Version: 10.0.4.216

Dead Horse Lane / Withers Lane / Driveway - Existing - PM Peak  
 Site Category: (None)  
 Give-Way (Two-Way)  
 Site Scenario: 1 | Local Volumes

Vehicle Movement Performance													
Mov ID	Turn	Mov Class	Demand Flows	Arrival Flows	Deg. Satn	Aver. Delay	Level of Service	95% Back Of Queue	Prop. Qued	Eff. Stop Rate	Number of Cycles to Depart	Aver. Speed	
			[ Total HV ]	[ Total HV ]	v/c	sec		[ Veh. Dist ]				km/h	
			veh/h	%	veh/h	%		veh	m				
South: Withers Lane (S)													
1	L2	All MCs	2 0.0	2 0.0	0.014	5.5	LOS A	0.0	0.1	0.01	0.07	0.01	56.9
2	T1	All MCs	23 0.0	23 0.0	0.014	0.0	LOS A	0.0	0.1	0.01	0.07	0.01	59.3
3	R2	All MCs	1 0.0	1 0.0	0.014	5.5	LOS A	0.0	0.1	0.01	0.07	0.01	56.5
Approach			26 0.0	26 0.0	0.014	0.7	NA	0.0	0.1	0.01	0.07	0.01	59.0
East: Dead Horse Lane													
4	L2	All MCs	1 0.0	1 0.0	0.002	5.6	LOS A	0.0	0.1	0.10	0.54	0.10	53.0
5	T1	All MCs	1 0.0	1 0.0	0.002	4.3	LOS A	0.0	0.1	0.10	0.54	0.10	53.4
6	R2	All MCs	1 0.0	1 0.0	0.002	5.6	LOS A	0.0	0.1	0.10	0.54	0.10	52.7
Approach			3 0.0	3 0.0	0.002	5.2	LOS A	0.0	0.1	0.10	0.54	0.10	53.0
North: Withers Lane (N)													
7	L2	All MCs	1 0.0	1 0.0	0.011	5.5	LOS A	0.0	0.1	0.01	0.06	0.01	57.0
8	T1	All MCs	20 0.0	20 0.0	0.011	0.0	LOS A	0.0	0.1	0.01	0.06	0.01	59.4
9	R2	All MCs	1 0.0	1 0.0	0.011	5.5	LOS A	0.0	0.1	0.01	0.06	0.01	56.7
Approach			22 0.0	22 0.0	0.011	0.5	NA	0.0	0.1	0.01	0.06	0.01	59.2
West: Local Driveway													
10	L2	All MCs	1 0.0	1 0.0	0.004	5.6	LOS A	0.0	0.1	0.11	0.55	0.11	52.8
11	T1	All MCs	1 0.0	1 0.0	0.004	4.3	LOS A	0.0	0.1	0.11	0.55	0.11	53.2
12	R2	All MCs	3 0.0	3 0.0	0.004	5.6	LOS A	0.0	0.1	0.11	0.55	0.11	52.6
Approach			5 0.0	5 0.0	0.004	5.4	LOS A	0.0	0.1	0.11	0.55	0.11	52.7
All Vehicles			57 0.0	57 0.0	0.014	1.3	NA	0.0	0.1	0.02	0.14	0.02	58.1

Site Level of Service (LOS) Method: Delay (SIDRA). Site LOS Method is specified in the Parameter Settings dialog (Options tab).  
 Vehicle movement LOS values are based on average delay per movement.  
 Minor Road Approach LOS values are based on average delay for all vehicle movements.  
 NA (TWSC): Level of Service is not defined for major road approaches or the intersection as a whole for Two-Way Sign Control (HCM LOS rule).  
 Two-Way Sign Control Capacity Model: SIDRA Standard.  
 Delay Model: SIDRA Standard (Control Delay: Geometric Delay is included).  
 Queue Model: SIDRA queue estimation methods are used for Back of Queue and Queue at Start of Gap.  
 Gap-Acceptance Capacity Formula: SIDRA Standard (Akçelik M3D).  
 HV (%) values are calculated for All Movement Classes of All Heavy Vehicle Model Designation.  
 Arrival Flows used in performance calculations are adjusted to include any Initial Queued Demand and Upstream Capacity Constraint effects.

# MOVEMENT SUMMARY

Site: [105] Dead Horse Lane / Midland Highway - Existing - AM Peak (Dead Horse Lane / Midland Highway)

Output produced by SIDRA INTERSECTION Version: 10.0.3.210

Dead Horse Lane / Midland Highway - Existing - AM Peak

Site Category: (None)

Give-Way (Two-Way)

Site Scenario: 1 | Local Volumes

Vehicle Movement Performance															
Mov ID	Turn	Mov Class	Demand Flows		Arrival Flows		Deg. Satn	Aver. Delay	Level of Service	95% Back Of Queue		Prop. Qued	Eff. Stop Rate	Number of Cycles to Depart	Aver. Speed
			[ Total HV ]	[ Total HV ]	[ Total HV ]	[ Total HV ]	v/c	sec		[ Veh. ]	[ Dist ]				km/h
			veh/h	%	veh/h	%				veh	m				
South: Midland Highway (S)															
1	L2	All MCs	2	2.0	2	2.0	0.080	5.8	LOS A	0.4	2.6	0.18	0.34	0.18	53.7
2	T1	All MCs	63	2.0	63	2.0	0.080	0.2	LOS A	0.4	2.6	0.18	0.34	0.18	55.9
3	R2	All MCs	75	2.0	75	2.0	0.080	5.8	LOS A	0.4	2.6	0.18	0.34	0.18	53.4
Approach			140	2.0	140	2.0	0.080	3.3	NA	0.4	2.6	0.18	0.34	0.18	54.5
East: Dead Horse Lane (E)															
4	L2	All MCs	67	2.0	67	2.0	0.076	5.8	LOS A	0.3	2.1	0.21	0.55	0.21	51.1
5	T1	All MCs	13	2.0	13	2.0	0.076	5.1	LOS A	0.3	2.1	0.21	0.55	0.21	51.5
6	R2	All MCs	17	2.0	17	2.0	0.076	6.7	LOS A	0.3	2.1	0.21	0.55	0.21	50.8
Approach			97	2.0	97	2.0	0.076	5.9	LOS A	0.3	2.1	0.21	0.55	0.21	51.1
North: Midland Highway (N)															
7	L2	All MCs	8	2.0	8	2.0	0.049	5.6	LOS A	0.0	0.1	0.01	0.07	0.01	56.6
8	T1	All MCs	82	2.0	82	2.0	0.049	0.0	LOS A	0.0	0.1	0.01	0.07	0.01	59.2
9	R2	All MCs	2	2.0	2	2.0	0.049	5.5	LOS A	0.0	0.1	0.01	0.07	0.01	56.3
Approach			93	2.0	93	2.0	0.049	0.6	NA	0.0	0.1	0.01	0.07	0.01	58.9
West: Dead Horse Lane (W)															
10	L2	All MCs	7	2.0	7	2.0	0.017	5.7	LOS A	0.1	0.4	0.22	0.54	0.22	50.2
11	T1	All MCs	3	2.0	3	2.0	0.017	5.1	LOS A	0.1	0.4	0.22	0.54	0.22	50.6
12	R2	All MCs	7	2.0	7	2.0	0.017	7.0	LOS A	0.1	0.4	0.22	0.54	0.22	50.0
Approach			18	2.0	18	2.0	0.017	6.1	LOS A	0.1	0.4	0.22	0.54	0.22	50.2
All Vehicles			347	2.0	347	2.0	0.080	3.4	NA	0.4	2.6	0.15	0.34	0.15	54.3

Site Level of Service (LOS) Method: Delay (SIDRA). Site LOS Method is specified in the Parameter Settings dialog (Options tab).

Vehicle movement LOS values are based on average delay per movement.

Minor Road Approach LOS values are based on average delay for all vehicle movements.

NA (TWSC): Level of Service is not defined for major road approaches or the intersection as a whole for Two-Way Sign Control (HCM LOS rule).

Two-Way Sign Control Capacity Model: SIDRA Standard.

Delay Model: SIDRA Standard (Control Delay: Geometric Delay is included).

Queue Model: SIDRA queue estimation methods are used for Back of Queue and Queue at Start of Gap.

Gap-Acceptance Capacity Formula: SIDRA Standard (Akçelik M3D).

HV (%) values are calculated for All Movement Classes of All Heavy Vehicle Model Designation.

Arrival Flows used in performance calculations are adjusted to include any Initial Queued Demand and Upstream Capacity Constraint effects.

SIDRA INTERSECTION 10.0 | Copyright © 2000-2025 Akcelik and Associates Pty Ltd | sidrasolutions.com

Organisation: RATIO CONSULTANTS PTY LTD | Licence: NETWORK / 1PC | Processed: Monday, 7 July 2025 11:48:32 AM

Project: C:\Users\conor.hogan\Ratio Consultants\22410T - Documents\Work\Analysis\SIDRA\22410T - SIDRA INTERSECTIONS - UPDATED ANALYSIS - RFI.sipx

# MOVEMENT SUMMARY

Site: [108] Dead Horse Lane / Midland Highway - Existing - PM Peak (Dead Horse Lane / Midland Highway)

Output produced by SIDRA INTERSECTION Version: 10.0.3.210

Dead Horse Lane / Midland Highway - Existing - PM Peak

Site Category: (None)

Give-Way (Two-Way)

Site Scenario: 1 | Local Volumes

Vehicle Movement Performance															
Mov ID	Turn	Mov Class	Demand Flows		Arrival Flows		Deg. Satn	Aver. Delay	Level of Service	95% Back Of Queue		Prop. Qued	Eff. Stop of Cycles	Number of Cycles	Aver. Speed
			[ Total HV ]	[ Total HV ]	[ Total HV ]	[ Total HV ]	v/c	sec		[ Veh. ]	[ Dist ]		Rate to Depart		km/h
			veh/h	%	veh/h	%				veh	m				
South: Midland Highway (S)															
1	L2	All MCs	3	2.0	3	2.0	0.104	5.9	LOS A	0.5	3.4	0.21	0.36	0.21	53.5
2	T1	All MCs	81	2.0	81	2.0	0.104	0.3	LOS A	0.5	3.4	0.21	0.36	0.21	55.8
3	R2	All MCs	96	2.0	96	2.0	0.104	5.8	LOS A	0.5	3.4	0.21	0.36	0.21	53.2
Approach			180	2.0	180	2.0	0.104	3.3	NA	0.5	3.4	0.21	0.36	0.21	54.4
East: Dead Horse Lane (E)															
4	L2	All MCs	80	2.0	80	2.0	0.090	5.9	LOS A	0.4	2.5	0.24	0.55	0.24	50.9
5	T1	All MCs	14	2.0	14	2.0	0.090	5.5	LOS A	0.4	2.5	0.24	0.55	0.24	51.3
6	R2	All MCs	18	2.0	18	2.0	0.090	7.2	LOS A	0.4	2.5	0.24	0.55	0.24	50.6
Approach			112	2.0	112	2.0	0.090	6.0	LOS A	0.4	2.5	0.24	0.55	0.24	50.9
North: Midland Highway (N)															
7	L2	All MCs	13	2.0	13	2.0	0.060	5.6	LOS A	0.0	0.1	0.01	0.07	0.01	56.7
8	T1	All MCs	101	2.0	101	2.0	0.060	0.0	LOS A	0.0	0.1	0.01	0.07	0.01	59.2
9	R2	All MCs	1	2.0	1	2.0	0.060	5.5	LOS A	0.0	0.1	0.01	0.07	0.01	56.4
Approach			115	2.0	115	2.0	0.060	0.7	NA	0.0	0.1	0.01	0.07	0.01	58.9
West: Dead Horse Lane (W)															
10	L2	All MCs	2	2.0	2	2.0	0.029	5.8	LOS A	0.1	0.7	0.35	0.58	0.35	50.3
11	T1	All MCs	14	2.0	14	2.0	0.029	5.4	LOS A	0.1	0.7	0.35	0.58	0.35	50.7
12	R2	All MCs	11	2.0	11	2.0	0.029	7.5	LOS A	0.1	0.7	0.35	0.58	0.35	50.0
Approach			26	2.0	26	2.0	0.029	6.2	LOS A	0.1	0.7	0.35	0.58	0.35	50.4
All Vehicles			433	2.0	433	2.0	0.104	3.5	NA	0.5	3.4	0.17	0.35	0.17	54.3

Site Level of Service (LOS) Method: Delay (SIDRA). Site LOS Method is specified in the Parameter Settings dialog (Options tab).

Vehicle movement LOS values are based on average delay per movement.

Minor Road Approach LOS values are based on average delay for all vehicle movements.

NA (TWSC): Level of Service is not defined for major road approaches or the intersection as a whole for Two-Way Sign Control (HCM LOS rule).

Two-Way Sign Control Capacity Model: SIDRA Standard.

Delay Model: SIDRA Standard (Control Delay: Geometric Delay is included).

Queue Model: SIDRA queue estimation methods are used for Back of Queue and Queue at Start of Gap.

Gap-Acceptance Capacity Formula: SIDRA Standard (Akçelik M3D).

HV (%) values are calculated for All Movement Classes of All Heavy Vehicle Model Designation.

Arrival Flows used in performance calculations are adjusted to include any Initial Queued Demand and Upstream Capacity Constraint effects.

SIDRA INTERSECTION 10.0 | Copyright © 2000-2025 Akcelik and Associates Pty Ltd | sidrasolutions.com

Organisation: RATIO CONSULTANTS PTY LTD | Licence: NETWORK / 1PC | Processed: Monday, 7 July 2025 11:48:33 AM

Project: C:\Users\conor.hogan\Ratio Consultants\22410T - Documents\Work\Analysis\SIDRA\22410T - SIDRA INTERSECTIONS - UPDATED ANALYSIS - RFI.sipx

# MOVEMENT SUMMARY

Site: [109] Dead Horse Lane / Stock Route - Existing - AM  
 Peak (Dead Horse Lane / Stock Route)

Output produced by SIDRA INTERSECTION Version: 10.0.4.216

Dead Horse Lane / Stock Route - Existing - AM Peak

Site Category: (None)

Give-Way (Two-Way)

Site Scenario: 1 | Local Volumes

Vehicle Movement Performance															
Mov ID	Turn	Mov Class	Demand Flows		Arrival Flows		Deg. Satn	Aver. Delay	Level of Service	95% Back Of Queue		Prop. Qued	Eff. Stop of Cycles	Number of Cycles to Depart	Aver. Speed
			[ Total HV ]	[ Total HV ]	[ Total HV ]	[ Total HV ]	v/c	sec		[ Veh. ]	[ Dist ]		Rate	Rate	km/h
			veh/h	%	veh/h	%				veh	m				
South: Stock Route															
1	L2	All MCs	2	0.0	2	0.0	0.002	5.6	LOS A	0.0	0.1	0.07	0.56	0.07	52.7
3	R2	All MCs	1	0.0	1	0.0	0.002	5.5	LOS A	0.0	0.1	0.07	0.56	0.07	52.4
Approach			3	0.0	3	0.0	0.002	5.6	LOS A	0.0	0.1	0.07	0.56	0.07	52.6
East: Dead Horse Lane (E)															
4	L2	All MCs	1	0.0	1	0.0	0.009	5.5	LOS A	0.0	0.0	0.00	0.04	0.00	57.2
5	T1	All MCs	16	0.0	16	0.0	0.009	0.0	LOS A	0.0	0.0	0.00	0.04	0.00	59.7
Approach			17	0.0	17	0.0	0.009	0.3	NA	0.0	0.0	0.00	0.04	0.00	59.5
West: Dead Horse Lane (W)															
11	T1	All MCs	9	0.0	9	0.0	0.009	0.0	LOS A	0.0	0.2	0.05	0.24	0.05	57.7
12	R2	All MCs	6	0.0	6	0.0	0.009	5.5	LOS A	0.0	0.2	0.05	0.24	0.05	55.1
Approach			16	0.0	16	0.0	0.009	2.2	NA	0.0	0.2	0.05	0.24	0.05	56.6
All Vehicles			36	0.0	36	0.0	0.009	1.6	NA	0.0	0.2	0.03	0.17	0.03	57.6

Site Level of Service (LOS) Method: Delay (SIDRA). Site LOS Method is specified in the Parameter Settings dialog (Options tab).

Vehicle movement LOS values are based on average delay per movement.

Minor Road Approach LOS values are based on average delay for all vehicle movements.

NA (TWSC): Level of Service is not defined for major road approaches or the intersection as a whole for Two-Way Sign Control (HCM LOS rule).

Two-Way Sign Control Capacity Model: SIDRA Standard.

Delay Model: SIDRA Standard (Control Delay: Geometric Delay is included).

Queue Model: SIDRA queue estimation methods are used for Back of Queue and Queue at Start of Gap.

Gap-Acceptance Capacity Formula: SIDRA Standard (Akçelik M3D).

HV (%) values are calculated for All Movement Classes of All Heavy Vehicle Model Designation.

Arrival Flows used in performance calculations are adjusted to include any Initial Queued Demand and Upstream Capacity Constraint effects.

SIDRA INTERSECTION 10.0 | Copyright © 2000-2025 Akcelik and Associates Pty Ltd | sidrasolutions.com

Organisation: RATIO CONSULTANTS PTY LTD | Licence: NETWORK / 1PC | Processed: Wednesday, 21 May 2025 12:20:20 AM

Project: C:\Users\conor.hogan\Ratio Consultants\22410T - Documents\Work\Analysis\SIDRA\22410T - SIDRA INTERSECTIONS - UPDATED ANALYSIS - RFI.sipx

# MOVEMENT SUMMARY

Site: [111] Dead Horse Lane / Stock Route - Existing - PM  
 Peak (Dead Horse Lane / Stock Route)

Output produced by SIDRA INTERSECTION Version: 10.0.4.216

Dead Horse Lane / Stock Route - Existing - PM Peak

Site Category: (None)

Give-Way (Two-Way)

Site Scenario: 1 | Local Volumes

Vehicle Movement Performance															
Mov ID	Turn	Mov Class	Demand Flows		Arrival Flows		Deg. Satn	Aver. Delay	Level of Service	95% Back Of Queue		Prop. Qued	Eff. Stop of Cycles	Number of Cycles	Aver. Speed
			[ Total HV ]	[ Total HV ]	[ Total HV ]	[ Total HV ]	v/c	sec		[ Veh. ]	[ Dist ]		Rate to Depart		km/h
			veh/h	%	veh/h	%				veh	m				
South: Stock Route															
1	L2	All MCs	1	0.0	1	0.0	0.002	5.6	LOS A	0.0	0.0	0.08	0.56	0.08	52.7
3	R2	All MCs	1	0.0	1	0.0	0.002	5.6	LOS A	0.0	0.0	0.08	0.56	0.08	52.4
Approach			2	0.0	2	0.0	0.002	5.6	LOS A	0.0	0.0	0.08	0.56	0.08	52.6
East: Dead Horse Lane (E)															
4	L2	All MCs	1	0.0	1	0.0	0.009	5.5	LOS A	0.0	0.0	0.00	0.04	0.00	57.2
5	T1	All MCs	17	0.0	17	0.0	0.009	0.0	LOS A	0.0	0.0	0.00	0.04	0.00	59.7
Approach			18	0.0	18	0.0	0.009	0.3	NA	0.0	0.0	0.00	0.04	0.00	59.5
West: Dead Horse Lane (W)															
11	T1	All MCs	24	0.0	24	0.0	0.014	0.0	LOS A	0.0	0.1	0.01	0.05	0.01	59.5
12	R2	All MCs	2	0.0	2	0.0	0.014	5.5	LOS A	0.0	0.1	0.01	0.05	0.01	56.7
Approach			26	0.0	26	0.0	0.014	0.4	NA	0.0	0.1	0.01	0.05	0.01	59.3
All Vehicles			46	0.0	46	0.0	0.014	0.6	NA	0.0	0.1	0.01	0.07	0.01	59.0

Site Level of Service (LOS) Method: Delay (SIDRA). Site LOS Method is specified in the Parameter Settings dialog (Options tab).

Vehicle movement LOS values are based on average delay per movement.

Minor Road Approach LOS values are based on average delay for all vehicle movements.

NA (TWSC): Level of Service is not defined for major road approaches or the intersection as a whole for Two-Way Sign Control (HCM LOS rule).

Two-Way Sign Control Capacity Model: SIDRA Standard.

Delay Model: SIDRA Standard (Control Delay: Geometric Delay is included).

Queue Model: SIDRA queue estimation methods are used for Back of Queue and Queue at Start of Gap.

Gap-Acceptance Capacity Formula: SIDRA Standard (Akçelik M3D).

HV (%) values are calculated for All Movement Classes of All Heavy Vehicle Model Designation.

Arrival Flows used in performance calculations are adjusted to include any Initial Queued Demand and Upstream Capacity Constraint effects.

SIDRA INTERSECTION 10.0 | Copyright © 2000-2025 Akcelik and Associates Pty Ltd | sidrasolutions.com

Organisation: RATIO CONSULTANTS PTY LTD | Licence: NETWORK / 1PC | Processed: Wednesday, 21 May 2025 12:20:21 AM

Project: C:\Users\conor.hogan\Ratio Consultants\22410T - Documents\Work\Analysis\SIDRA\22410T - SIDRA INTERSECTIONS - UPDATED ANALYSIS - RFI.sipx

# MOVEMENT SUMMARY

**STOP** Site: [115] Maroondah Highway / Withers Lane / Kidstone Parade - Existing - AM Peak (Maroondah Highway / Withers Lane / Kidston Parade)

Output produced by SIDRA INTERSECTION Version: 10.0.3.210

Maroondah Highway / Withers Lane / Kidstone Parade - Existing - AM Peak

Site Category: (None)

Stop (Two-Way)

Site Scenario: 1 | Local Volumes

Vehicle Movement Performance															
Mov ID	Turn	Mov Class	Demand Flows		Arrival Flows		Deg. Satn	Aver. Delay	Level of Service	95% Back Of Queue		Prop. Qued	Eff. Stop Rate	Number of Cycles to Depart	Aver. Speed
			[ Total HV ]	%	[ Total HV ]	%	v/c	sec		[ Veh. ]	[ Dist ]				km/h
			veh/h		veh/h					veh	m				
South: Kidston Parade															
1	L2	All MCs	23	2.0	23	2.0	0.054	8.7	LOS A	0.2	1.4	0.36	0.87	0.36	48.2
2	T1	All MCs	6	2.0	6	2.0	0.054	10.3	LOS B	0.2	1.4	0.36	0.87	0.36	48.2
3	R2	All MCs	16	2.0	16	2.0	0.054	10.9	LOS B	0.2	1.4	0.36	0.87	0.36	48.0
Approach			45	2.0	45	2.0	0.054	9.7	LOS A	0.2	1.4	0.36	0.87	0.36	48.1
East: Maroondah Highway (E)															
4	L2	All MCs	17	2.0	17	2.0	0.102	6.0	LOS A	0.2	1.2	0.10	0.16	0.10	54.6
5	T1	All MCs	155	2.0	155	2.0	0.102	0.1	LOS A	0.2	1.2	0.10	0.16	0.10	56.9
6	R2	All MCs	18	2.0	18	2.0	0.102	6.3	LOS A	0.2	1.2	0.10	0.16	0.10	54.3
Approach			189	2.0	189	2.0	0.102	1.2	NA	0.2	1.2	0.10	0.16	0.10	56.4
North: Withers Lane															
7	L2	All MCs	21	2.0	21	2.0	0.045	9.0	LOS A	0.2	1.1	0.39	0.88	0.39	48.5
8	T1	All MCs	7	2.0	7	2.0	0.045	10.3	LOS B	0.2	1.1	0.39	0.88	0.39	48.5
9	R2	All MCs	9	2.0	9	2.0	0.045	10.8	LOS B	0.2	1.1	0.39	0.88	0.39	48.3
Approach			38	2.0	38	2.0	0.045	9.7	LOS A	0.2	1.1	0.39	0.88	0.39	48.4
West: Maroondah Highway (W)															
10	L2	All MCs	5	2.0	5	2.0	0.131	6.1	LOS A	0.1	0.9	0.05	0.08	0.05	55.3
11	T1	All MCs	225	2.0	225	2.0	0.131	0.1	LOS A	0.1	0.9	0.05	0.08	0.05	57.7
12	R2	All MCs	16	2.0	16	2.0	0.131	6.1	LOS A	0.1	0.9	0.05	0.08	0.05	55.0
Approach			246	2.0	246	2.0	0.131	0.6	NA	0.1	0.9	0.05	0.08	0.05	57.5
All Vehicles			519	2.0	519	2.0	0.131	2.3	NA	0.2	1.4	0.12	0.23	0.12	55.4

Site Level of Service (LOS) Method: Delay (SIDRA). Site LOS Method is specified in the Parameter Settings dialog (Options tab).

Vehicle movement LOS values are based on average delay per movement.

Minor Road Approach LOS values are based on average delay for all vehicle movements.

NA (TWSC): Level of Service is not defined for major road approaches or the intersection as a whole for Two-Way Sign Control (HCM LOS rule).

Two-Way Sign Control Capacity Model: SIDRA Standard.

Delay Model: SIDRA Standard (Control Delay: Geometric Delay is included).

Queue Model: SIDRA queue estimation methods are used for Back of Queue and Queue at Start of Gap.

Gap-Acceptance Capacity Formula: SIDRA Standard (Akçelik M3D).

HV (%) values are calculated for All Movement Classes of All Heavy Vehicle Model Designation.

Arrival Flows used in performance calculations are adjusted to include any Initial Queued Demand and Upstream Capacity Constraint effects.

**SIDRA INTERSECTION 10.0 | Copyright © 2000-2025 Akcelik and Associates Pty Ltd | sidrasolutions.com**

Organisation: RATIO CONSULTANTS PTY LTD | Licence: NETWORK / 1PC | Processed: Monday, 7 July 2025 11:48:38 AM

Project: C:\Users\conor.hogan\Ratio Consultants\22410T - Documents\Work\Analysis\SIDRA\22410T - SIDRA INTERSECTIONS - UPDATED ANALYSIS - RFI.sipx

# MOVEMENT SUMMARY

**STOP** Site: [116] Maroondah Highway / Withers Lane / Kidstone Parade - Existing - PM Peak (Maroondah Highway / Withers Lane / Kidston Parade)

Output produced by SIDRA INTERSECTION Version: 10.0.3.210

Maroondah Highway / Withers Lane / Kidstone Parade - Existing - PM Peak

Site Category: (None)

Stop (Two-Way)

Site Scenario: 1 | Local Volumes

Vehicle Movement Performance															
Mov ID	Turn	Mov Class	Demand Flows		Arrival Flows		Deg. Satn	Aver. Delay	Level of Service	95% Back Of Queue		Prop. Qued	Eff. Stop Rate	Number of Cycles to Depart	Aver. Speed
			[ Total HV ]	%	[ Total HV ]	%	v/c	sec		[ Veh. ]	[ Dist ]				km/h
			veh/h		veh/h					veh	m				
South: Kidston Parade															
1	L2	All MCs	27	2.0	27	2.0	0.075	8.9	LOS A	0.3	1.9	0.39	0.89	0.39	48.3
2	T1	All MCs	8	2.0	8	2.0	0.075	10.1	LOS B	0.3	1.9	0.39	0.89	0.39	48.3
3	R2	All MCs	25	2.0	25	2.0	0.075	10.6	LOS B	0.3	1.9	0.39	0.89	0.39	48.1
Approach			61	2.0	61	2.0	0.075	9.8	LOS A	0.3	1.9	0.39	0.89	0.39	48.2
East: Maroondah Highway (E)															
4	L2	All MCs	31	2.0	31	2.0	0.129	5.8	LOS A	0.2	1.4	0.08	0.16	0.08	54.7
5	T1	All MCs	187	2.0	187	2.0	0.129	0.1	LOS A	0.2	1.4	0.08	0.16	0.08	57.1
6	R2	All MCs	22	2.0	22	2.0	0.129	6.0	LOS A	0.2	1.4	0.08	0.16	0.08	54.4
Approach			240	2.0	240	2.0	0.129	1.4	NA	0.2	1.4	0.08	0.16	0.08	56.5
North: Withers Lane															
7	L2	All MCs	23	2.0	23	2.0	0.048	8.7	LOS A	0.2	1.2	0.34	0.88	0.34	48.5
8	T1	All MCs	9	2.0	9	2.0	0.048	10.2	LOS B	0.2	1.2	0.34	0.88	0.34	48.5
9	R2	All MCs	11	2.0	11	2.0	0.048	10.5	LOS B	0.2	1.2	0.34	0.88	0.34	48.3
Approach			43	2.0	43	2.0	0.048	9.4	LOS A	0.2	1.2	0.34	0.88	0.34	48.4
West: Maroondah Highway (W)															
10	L2	All MCs	12	2.0	12	2.0	0.094	6.1	LOS A	0.1	1.0	0.09	0.14	0.09	54.7
11	T1	All MCs	145	2.0	145	2.0	0.094	0.1	LOS A	0.1	1.0	0.09	0.14	0.09	57.1
12	R2	All MCs	17	2.0	17	2.0	0.094	6.2	LOS A	0.1	1.0	0.09	0.14	0.09	54.4
Approach			174	2.0	174	2.0	0.094	1.1	NA	0.1	1.0	0.09	0.14	0.09	56.6
All Vehicles			518	2.0	518	2.0	0.129	2.9	NA	0.3	1.9	0.14	0.30	0.14	54.7

Site Level of Service (LOS) Method: Delay (SIDRA). Site LOS Method is specified in the Parameter Settings dialog (Options tab).

Vehicle movement LOS values are based on average delay per movement.

Minor Road Approach LOS values are based on average delay for all vehicle movements.

NA (TWSC): Level of Service is not defined for major road approaches or the intersection as a whole for Two-Way Sign Control (HCM LOS rule).

Two-Way Sign Control Capacity Model: SIDRA Standard.

Delay Model: SIDRA Standard (Control Delay: Geometric Delay is included).

Queue Model: SIDRA queue estimation methods are used for Back of Queue and Queue at Start of Gap.

Gap-Acceptance Capacity Formula: SIDRA Standard (Akçelik M3D).

HV (%) values are calculated for All Movement Classes of All Heavy Vehicle Model Designation.

Arrival Flows used in performance calculations are adjusted to include any Initial Queued Demand and Upstream Capacity Constraint effects.

**SIDRA INTERSECTION 10.0 | Copyright © 2000-2025 Akcelik and Associates Pty Ltd | sidrasolutions.com**

Organisation: RATIO CONSULTANTS PTY LTD | Licence: NETWORK / 1PC | Processed: Monday, 7 July 2025 11:48:38 AM

Project: C:\Users\conor.hogan\Ratio Consultants\22410T - Documents\Work\Analysis\SIDRA\22410T - SIDRA INTERSECTIONS - UPDATED ANALYSIS - RFI.sipx

# Appendix D – Swept Path Assessment

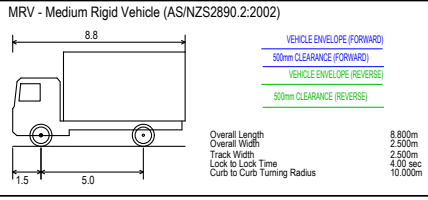
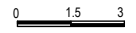
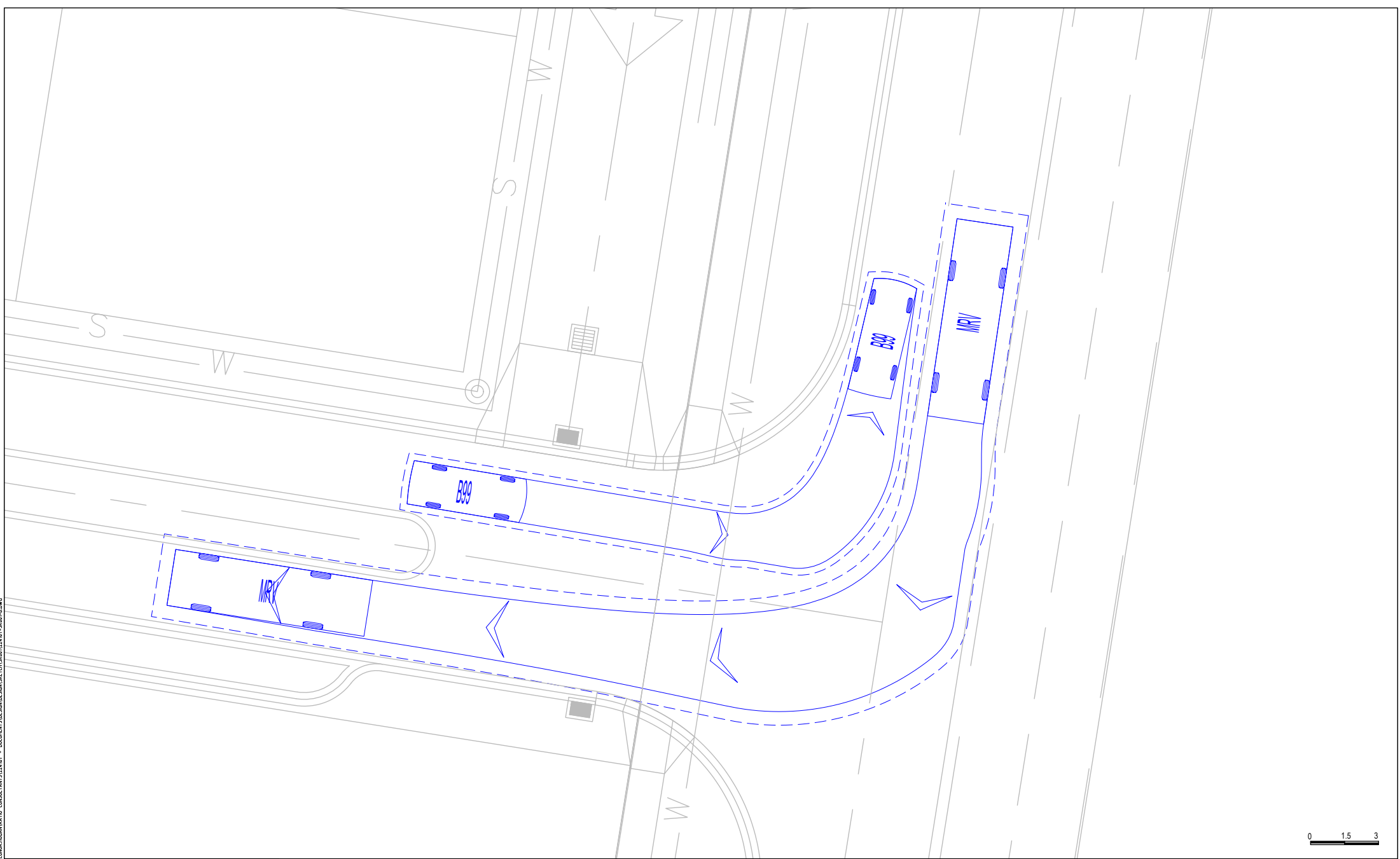

Proposed Retirement Village  
 57 Stock Route, Mansfield  
 Swept Path Assessment

NOTE:  
 1) Base Plan Supplied By Millar Merrigan  
 2) Maximum Design Speed 10km/h

RATIO REFERENCE 22410T-SK001-B	SHEET No. 1 of 4	PREPARED BY C.L.H	SCALE 1:150@A3	DATE 21/05/2025
-----------------------------------	---------------------	----------------------	-------------------	--------------------



C:\USERS\CONR-ROD\DRAWING\CONSULTANTS\22410T-SK001\22410T-SK001-B.DWG

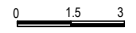
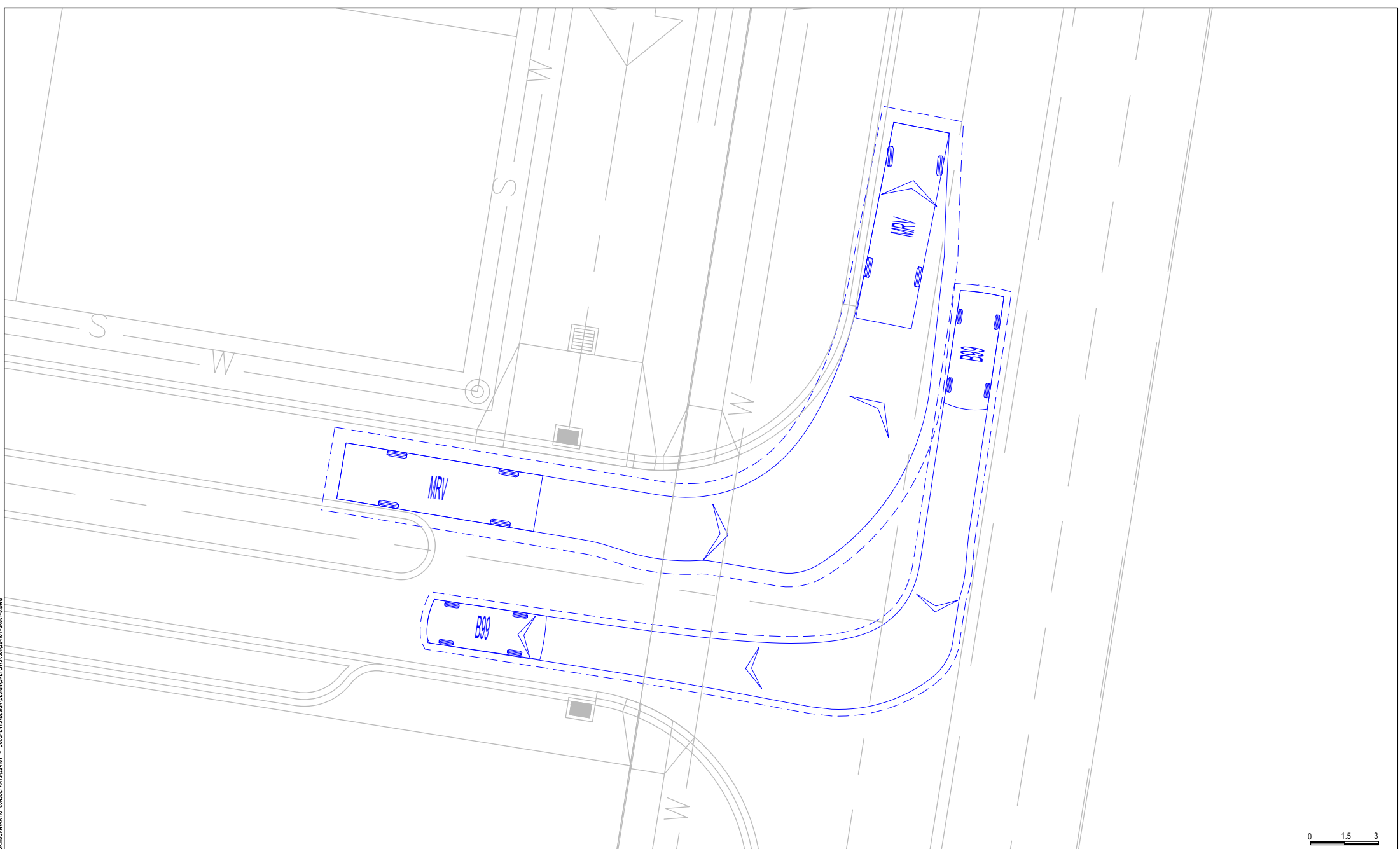

**ratio:**  
 RATIO CONSULTANTS PTY LTD  
 ABN 005 422 104  
 LEVEL 5, 65 DOVER STREET  
 CREMORNE, VICTORIA 3121  
 TELEPHONE (03)9429 3111  
 FACSIMILE (03)9429 3011

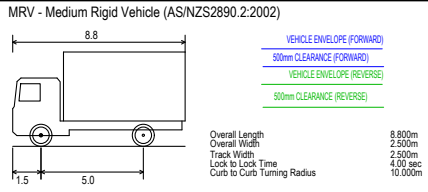

### Proposed Retirement Village 57 Stock Route, Mansfield Swept Path Assessment

NOTE:  
 1) Base Plan Supplied By Melliar Merrigan  
 2) Maximum Design Speed 10km/h

RATIO REFERENCE 22410T-SK001-B	SHEET No. 2 of 4	PREPARED BY C.L.H	SCALE 1:150@A3	DATE 21/05/2025
-----------------------------------	---------------------	----------------------	-------------------	--------------------



C:\USERS\CONR-ROD\DRAWING\CONSULTANTS\2025\22410T-SK001-B.DWG

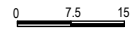
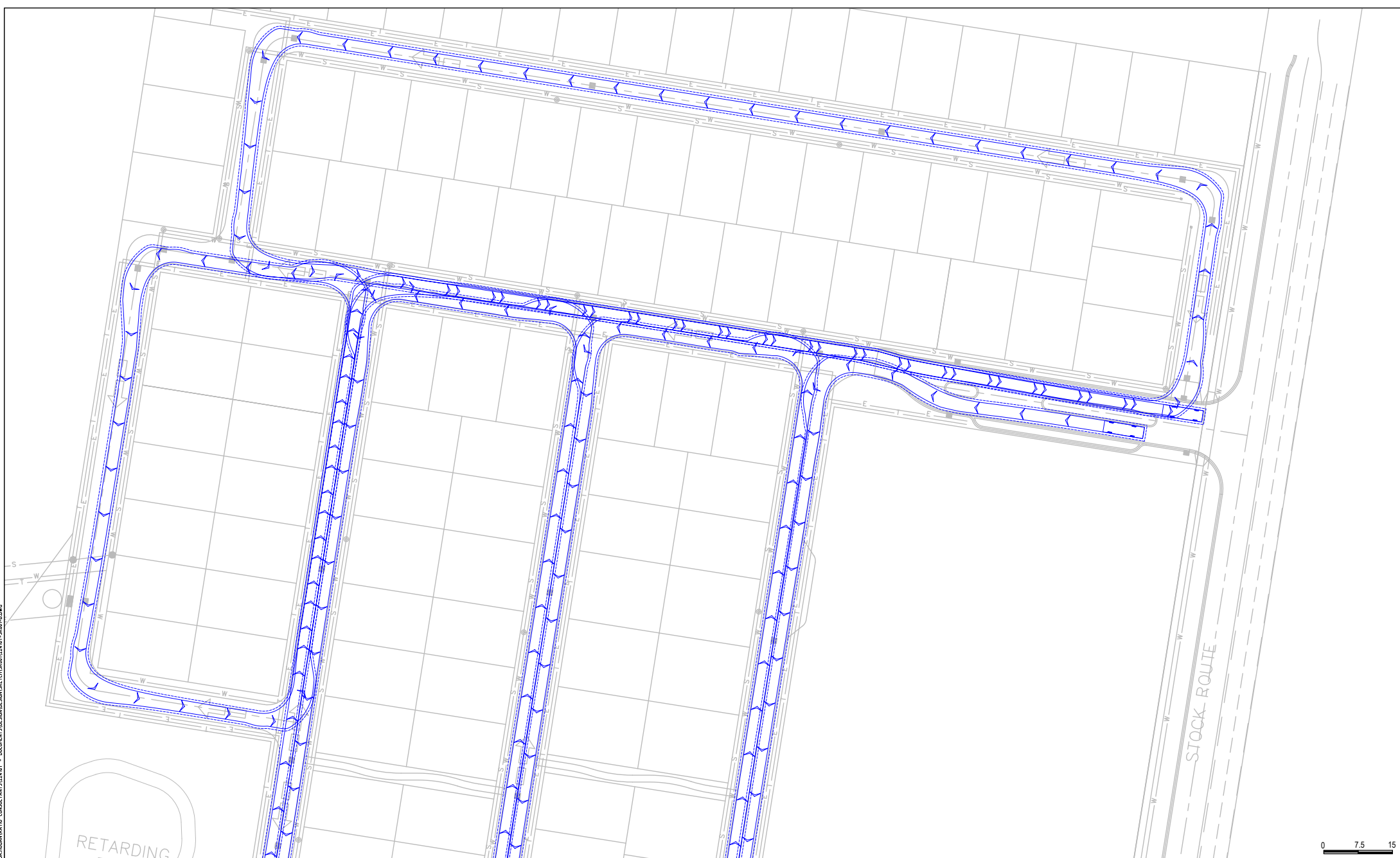

**ratio:**  
 RATIO CONSULTANTS PTY LTD  
 ABN 005 422 104  
 LEVEL 5, 65 DOVER STREET  
 CREMORNE, VICTORIA 3121  
 TELEPHONE (03)9429 3111  
 FACSIMILE (03)9429 3011

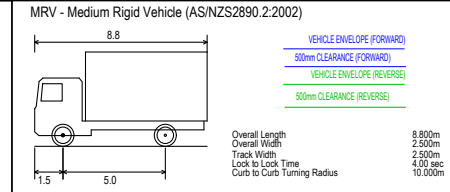

### Proposed Retirement Village

#### 57 Stock Route, Mansfield

#### Swept Path Assessment

NOTE:  
 1) Base Plan Supplied By Melliar Merrigan  
 2) Maximum Design Speed 10km/h



RATIO REFERENCE 22410T-SK001-B	SHEET No. 3 of 4	PREPARED BY C.L.H	SCALE 1:750@A3	DATE 21/05/2025
-----------------------------------	---------------------	----------------------	-------------------	--------------------

C:\USERS\CONOR\HOUSING\PROJECTS\CONSULTANTS\CONSULTANTS\PROJECTS\22410T-SK001-B.DWG  
 27/05/2025 5:41:08 PM

RETARDING BASIN

STOCK ROUTE

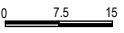

RATIO CONSULTANTS PTY LTD  
 ABN 005 422 104  
 LEVEL 5, 65 DOVER STREET  
 CREMORNE, VICTORIA 3121  
 TELEPHONE (03)9429 3111  
 FACSIMILE (03)9429 3011

MRV - Medium Rigid Vehicle (AS/NZS2890.2:2002)

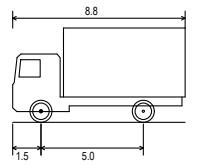

- VEHICLE ENVELOPE (FORWARD)
- 500mm CLEARANCE (FORWARD)
- VEHICLE ENVELOPE (REVERSE)
- 500mm CLEARANCE (REVERSE)

### Proposed Retirement Village 57 Stock Route, Mansfield Swept Path Assessment

NOTE:  
 1) Base Plan Supplied By Mellar Merrigan  
 2) Maximum Design Speed 10km/h

RATIO REFERENCE  
 22410T-SK001-B

SHEET No.  
 4 of 4

PREPARED BY  
 C.L.H

SCALE  
 1:750@A3

DATE  
 21/05/2025



C:\USERS\CONR-RODAM\PATD - CONSULTANTS\PROJECTS\22410T-SK001\22410T-SK001-B.DWG 27/05/2025 5:41:08 PM

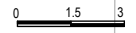
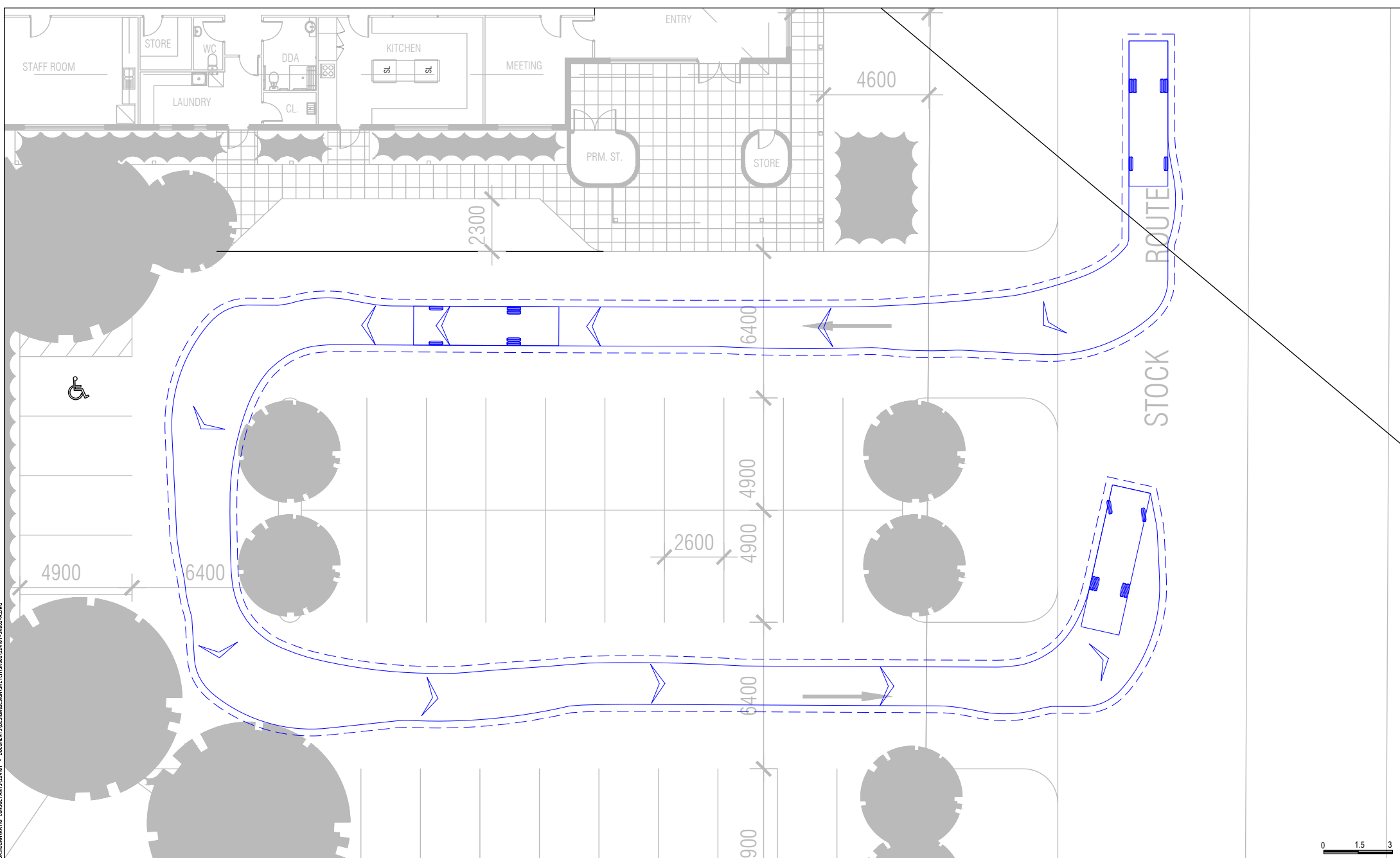

C:\USERS\CONR-ROD\DRAWING\CONSULTANTS\22410T - DOCUMENTS\DESIGN\DWG\22410T-20002-ADWG

**ratio:**  
 RATIO CONSULTANTS PTY LTD  
 ABN 005 422 104  
 LEVEL 5, 65 DOVER STREET  
 CREMORNE, VICTORIA 3121  
 TELEPHONE (03)9429 3111  
 FACSIMILE (03)9429 3011

Mini-Rear Loader Waste Collection Vehicle

Overall Length 6345m  
 Body Width 1700m  
 Overall Body Height 2080m  
 Min Body Ground Clearance 0.205m  
 Track Width 1.670m  
 Lock to Lock Time 4.00 sec  
 Curb to Curb Turning Radius 6.450m

Proposed Childcare Centre  
 57 Stock Route, Mansfield  
 Waste Vehicle Swept Path Assessment

NOTE:  
 1) Base Plan Supplied By Springtree  
 2) Maximum Design Speed 10km/h

RATIO REFERENCE 22410T-SK002-A	SHEET No. 1 of 1	PREPARED BY C.L.H	SCALE 1:150@A3	DATE 06/06/2025
-----------------------------------	---------------------	----------------------	-------------------	--------------------



# Appendix E – Traffix Group Case Study

3 March 2020

## Case Study – Lifestyle Village in Bittern

### Introduction

Traffix Group has undertaken a case study of an existing lifestyle village located at 17 Booker Rise, Bittern. The facility is operated by 'Lifestyle Communities'. The results of this Case Study can be used as empirical evidence when undertaking traffic generation assessments or parking demand assessments for proposed developments of new lifestyle villages.

### Case Study Area



Source: NearMap

Figure 1: Subject Area

The case study area is located to the west of Frankston-Flinders Road, Bittern, approximately 60km southeast of the Melbourne CBD. The site is located within the Mornington Peninsula Shire.

Access to the lifestyle village is provided by a single vehicle connection with Booker Rise, a local road that extends to the west from Frankston-Flinders Road.

The lifestyle village contains 210 units, with various associated community buildings that we understand are typically only used by residents of the village. Dwellings within the village have an attached single garage.

Resident parking is mostly within single garages, with a tandem space also provided in some instances in front of the single garages. A total of 34 shared visitor/staff parking

spaces are included on-site, which includes two (2) disabled parking spaces. Two (2) parking spaces are also allocated to the site's electric 'pool' cars.

A map of the current parking areas within the site is provided at Figure 2.



Source: NearMap

Figure 2: On-site Visitor/Staff Parking Locations

## Data Collection

Traffix Group commissioned traffic counts (tube counts) at the vehicle access point with Booker Place. These counts were undertaken for the duration of a week, between Wednesday 5<sup>th</sup> February and Wednesday 12<sup>th</sup> February, 2020. Full output is attached at Appendix A.

Traffix Group also visited the site to undertake surveys of the onsite visitor/staff parking during a typical weekday. The parking surveys were completed between 10am and 1pm on Monday 2<sup>nd</sup> March, 2020, at 30-minute intervals, with vehicles parked within the onsite parking facilities and along the site's internal roads counted.

We were advised that a total of 202 dwellings were occupied at the time of our traffic counts.



## Results

### Traffic Generation

A daily average volume of 692 daily vehicle movements was recorded for weekdays across the data collection period. This includes 347 entry and 345 exit movements.

This corresponds to a weekday traffic generation rate of **3.43 daily vehicle trips per occupied dwelling**.

A profile of traffic volumes across weekdays is shown at Figure 3.

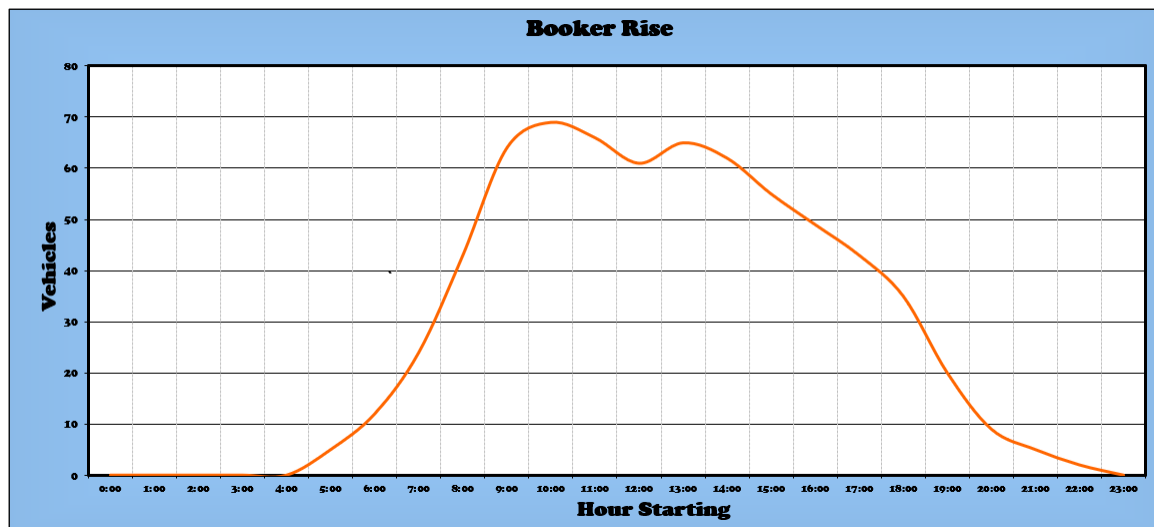

Source: Trans Traffic Survey

Figure 3: Weekday Traffic Volume Distribution

The peak hour for site generated traffic occurred between 10am and 11am, which is outside of the typical AM and PM commuter peak hours and the typical school 'drop-off' and 'pick-up' periods.

The weekday peak hour traffic generation rates are:

- AM commuter peak hour traffic generation of **0.22 vehicle trips per occupied dwelling**
- PM commuter peak hour traffic generation of **0.22 vehicle trips per occupied dwelling**
- Site commuter peak hour traffic generation of **0.34 vehicle trips per occupied dwelling**

Traffic movements on weekend days were considerably lower than on weekdays.

Table 1 shows the recorded site peak hour volumes and the typical AM and PM commuter peak hour volumes and entry/exit proportions.



Table 1: Peak Hour Entry/Exit Distribution

	AM Peak Hour (8-9am)		PM Peak Hour (5-6pm)		Site Peak Hour (10-11am)	
	Average Weekday Trips	%	Average Weekday Trips	%	Average Weekday Trips	%
Entry Movements	14	31.8%	29	65.9%	27	39.1%
Exit Movements	30	68.2%	15	34.1%	42	60.9%
<b>Total</b>	<b>44</b>	<b>100%</b>	<b>44</b>	<b>100%</b>	<b>69</b>	<b>100%</b>

### Visitor Parking

A total of 34 visitor/staff car parking spaces are located onsite (a provision of **0.17 visitor/staff spaces per dwelling**), which includes two (2) disabled parking spaces. The results of parking surveys undertaken between 10am and 1pm on Monday 2<sup>nd</sup> March, 2020 are provided at Table 2.

Table 2: Parking Survey Count Summary - Visitor Parking Demands

	Capacity	10am	10:30am	11am	11:30am	12noon	12:30pm
Car Park 1	<b>10</b>	2	4	6	4	7	3
Car Park 2	<b>18</b>	5	5	5	4	5	5
Car Park 3	<b>6</b>	6	4	3	3	2	1
<b>Total</b>	<b>34</b>	<b>13</b>	<b>13</b>	<b>14</b>	<b>11</b>	<b>14</b>	<b>9</b>

The peak occupancy of the parking facilities occurred at both 11am and 12noon, when there were 14 parked cars<sup>1</sup> (41% occupancy). The peak parking generation rate for visitor/staff spaces in the parking facilities is **0.07 vehicles per occupied dwelling**.

Informal parking is also available at the frontage of each dwelling. The maximum number of cars parked on-street was nine (9) vehicles, which occurred at both 10:30am and 11am.

The peak parking requirement for staff/visitors for this use is therefore **0.11 vehicles per occupied dwelling**.

The onsite caravan parking was also at maximum capacity (11 spaces) throughout the entire survey period. Based on this, caravan ownership for this use is **0.054 vehicles per occupied dwelling**.

<sup>1</sup> During the 11am parking survey, both disabled parking spaces were vacant, whereas during the 12noon parking survey, both disabled parking spaces were occupied.





# **Appendix A**

## **Traffic Count Results**

Traffic Counts - Both Directions

Day	Monday	Tuesday	Wednesday	Thursday	Friday	Saturday	Sunday	7 days		Weekday		Weekend	
Date	10/02/2020	11/02/2020	5/02/2020	6/02/2020	7/02/2020	8/02/2020	9/02/2020	Total	Average	Total	Average	Total	Average
AM Peak	09:00	09:00	09:00	10:00	10:00	11:00	11:00	N/A	11:00	N/A	10:00	N/A	11:00
PM Peak	14:00	14:00	13:00	14:00	13:00	12:00	12:00	N/A	13:00	N/A	13:00	N/A	12:00
00:00	1	0	0	0	0	0	3	4	1	1	0	3	2
01:00	0	0	0	0	1	0	0	1	0	1	0	0	0
02:00	0	0	0	1	0	1	0	2	0	1	0	1	1
03:00	0	0	0	0	0	0	0	0	0	0	0	0	0
04:00	0	0	0	1	0	0	0	1	0	1	0	0	0
05:00	6	3	3	5	6	3	3	29	4	23	5	6	3
06:00	11	15	15	10	11	2	5	69	10	62	12	7	4
07:00	29	17	18	32	24	2	5	127	18	120	24	7	4
08:00	50	38	47	56	28	24	16	259	37	219	44	40	20
09:00	59	60	72	61	70	41	35	398	57	322	64	76	38
10:00	59	59	72	67	86	58	31	432	62	343	69	89	45
11:00	59	60	64	64	84	78	52	461	66	331	66	130	65
12:00	62	53	69	57	61	59	57	418	60	302	60	116	58
13:00	57	56	74	62	73	59	55	436	62	322	64	114	57
14:00	64	68	58	72	51	38	55	406	58	313	63	93	47
15:00	55	54	47	60	59	46	48	369	53	275	55	94	47
16:00	51	56	48	49	42	45	53	344	49	246	49	98	49
17:00	46	42	45	42	44	40	37	296	42	219	44	77	39
18:00	46	36	31	30	34	21	30	228	33	177	35	51	26
19:00	16	28	19	19	20	8	12	122	17	102	20	20	10
20:00	3	11	12	5	14	2	12	59	8	45	9	14	7
21:00	2	6	6	5	5	2	4	30	4	24	5	6	3
22:00	0	1	0	3	5	5	2	16	2	9	2	7	4
23:00	0	0	0	1	1	5	1	8	1	2	0	6	3
Total	676	663	700	702	719	539	516	4515	644	3460	690	1055	532
% Heavy	1.63%	1.51%	1.86%	1.42%	1.67%	0.74%	1.16%	1.46%		1.62%		0.95%	

Traffic Counts - Northbound

Day	Monday	Tuesday	Wednesday	Thursday	Friday	Saturday	Sunday	7 days		Weekday		Weekend	
Date	10/02/2020	11/02/2020	5/02/2020	6/02/2020	7/02/2020	8/02/2020	9/02/2020	Total	Average	Total	Average	Total	Average
AM Peak	09:00	09:00	09:00	09:00	10:00	11:00	11:00	N/A	09:00	N/A	09:00	N/A	11:00
PM Peak	14:00	14:00	13:00	13:00	12:00	13:00	12:00	N/A	12:00	N/A	13:00	N/A	12:00
00:00	0	0	0	0	0	0	2	2	0	0	0	2	1
01:00	0	0	0	0	0	0	0	0	0	0	0	0	0
02:00	0	0	0	1	0	1	0	2	0	1	0	1	1
03:00	0	0	0	0	0	0	0	0	0	0	0	0	0
04:00	0	0	0	1	0	0	0	1	0	1	0	0	0
05:00	5	2	3	4	5	2	3	24	3	19	4	5	3
06:00	10	12	9	7	8	2	3	51	7	46	9	5	3
07:00	21	10	17	23	18	1	5	95	14	89	18	6	3
08:00	34	26	33	39	18	18	14	182	26	150	30	32	16
09:00	37	45	48	44	47	31	26	278	40	221	44	57	29
10:00	37	31	47	41	52	35	23	266	38	208	42	58	29
11:00	27	33	37	32	48	44	39	260	37	177	35	83	42
12:00	28	22	27	29	30	24	34	194	28	136	27	58	29
13:00	26	24	32	30	29	25	20	186	27	141	28	45	23
14:00	33	36	28	25	18	16	18	174	25	140	28	34	17
15:00	28	22	18	23	25	21	19	156	22	116	23	40	20
16:00	16	16	11	15	16	22	21	117	17	74	15	43	22
17:00	11	20	16	13	16	16	12	104	15	76	15	28	14
18:00	17	15	15	10	15	5	13	90	13	72	14	18	9
19:00	1	11	4	7	5	5	6	39	6	28	6	11	6
20:00	0	2	3	3	10	2	3	23	3	18	4	5	3
21:00	1	2	1	4	1	0	0	9	1	9	2	0	0
22:00	0	0	0	0	1	0	1	2	0	1	0	1	1
23:00	0	0	0	0	0	2	0	2	0	0	0	2	1
Total	332	329	349	351	362	272	262	2257	322	1723	344	534	272
% Heavy	1.51%	1.52%	1.72%	1.71%	1.66%	0.74%	1.15%	1.46%		1.63%		0.94%	

Traffic Counts - Southbound

Day	Monday	Tuesday	Wednesday	Thursday	Friday	Saturday	Sunday	7 days		Weekday		Weekend	
Date	10/02/2020	11/02/2020	5/02/2020	6/02/2020	7/02/2020	8/02/2020	9/02/2020	Total	Average	Total	Average	Total	Average
AM Peak	11:00	10:00	11:00	11:00	11:00	11:00	11:00	N/A	11:00	N/A	11:00	N/A	11:00
PM Peak	16:00	16:00	12:00	14:00	13:00	12:00	14:00	N/A	13:00	N/A	13:00	N/A	13:00
00:00	1	0	0	0	0	0	1	2	0	1	0	1	1
01:00	0	0	0	0	1	0	0	1	0	1	0	0	0
02:00	0	0	0	0	0	0	0	0	0	0	0	0	0
03:00	0	0	0	0	0	0	0	0	0	0	0	0	0
04:00	0	0	0	0	0	0	0	0	0	0	0	0	0
05:00	1	1	0	1	1	1	0	5	1	4	1	1	1
06:00	1	3	6	3	3	0	2	18	3	16	3	2	1
07:00	8	7	1	9	6	1	0	32	5	31	6	1	1
08:00	16	12	14	17	10	6	2	77	11	69	14	8	4
09:00	22	15	24	17	23	10	9	120	17	101	20	19	10
10:00	22	28	25	26	34	23	8	166	24	135	27	31	16
11:00	32	27	27	32	36	34	13	201	29	154	31	47	24
12:00	34	31	42	28	31	35	23	224	32	166	33	58	29
13:00	31	32	42	32	44	34	35	250	36	181	36	69	35
14:00	31	32	30	47	33	22	37	232	33	173	35	59	30
15:00	27	32	29	37	34	25	29	213	30	159	32	54	27
16:00	35	40	37	34	26	23	32	227	32	172	34	55	28
17:00	35	22	29	29	28	24	25	192	27	143	29	49	25
18:00	29	21	16	20	19	16	17	138	20	105	21	33	17
19:00	15	17	15	12	15	3	6	83	12	74	15	9	5
20:00	3	9	9	2	4	0	9	36	5	27	5	9	5
21:00	1	4	5	1	4	2	4	21	3	15	3	6	3
22:00	0	1	0	3	4	5	1	14	2	8	2	6	3
23:00	0	0	0	1	1	3	1	6	1	2	0	4	2
Total	344	334	351	351	357	267	254	2258	323	1737	347	521	267
% Heavy	1.74%	1.50%	1.99%	1.14%	1.68%	0.75%	1.18%	1.46%		1.61%		0.96%	

# Appendix F – Post Development SIDRA Results

# MOVEMENT SUMMARY

Site: [102] Dead Horse Lane / Withers Lane / Driveway - Post Development - AM Peak (Dead Horse Lane / Withers Lane / Driveway)

Output produced by SIDRA INTERSECTION Version: 10.0.3.210

Dead Horse Lane / Withers Lane / Driveway - Post Development - AM Peak

Site Category: (None)

Give-Way (Two-Way)

Site Scenario: 1 | Local Volumes

Vehicle Movement Performance															
Mov ID	Turn	Mov Class	Demand Flows		Arrival Flows		Deg. Satn	Aver. Delay	Level of Service	95% Back Of Queue		Prop. Qued	Eff. Stop Rate	Number of Cycles to Depart	Aver. Speed
			[ Total HV ]	[ Total HV ]	[ Total HV ]	[ Total HV ]	v/c	sec		[ Veh. ]	[ Dist ]				km/h
			veh/h	%	veh/h	%				veh	m				
South: Withers Lane (S)															
1a	L1	All MCs	18	2.0	18	2.0	0.030	5.3	LOSA	0.1	1.0	0.01	0.59	0.01	52.6
3	R2	All MCs	37	2.0	37	2.0	0.030	5.5	LOSA	0.1	1.0	0.01	0.59	0.01	52.5
Approach			55	2.0	55	2.0	0.030	5.4	NA	0.1	1.0	0.01	0.59	0.01	52.5
East: Dead Horse Lane															
4	L2	All MCs	44	2.0	44	2.0	0.025	5.6	LOSA	0.0	0.0	0.00	0.57	0.00	52.8
6a	R1	All MCs	1	2.0	1	2.0	0.025	5.0	LOSA	0.0	0.0	0.00	0.57	0.00	52.7
Approach			45	2.0	45	2.0	0.025	5.6	NA	0.0	0.0	0.00	0.57	0.00	52.8
NorthWest: Withers Lane (N)															
27a	L1	All MCs	1	2.0	1	2.0	0.010	5.4	LOSA	0.0	0.2	0.15	0.54	0.15	51.6
29a	R1	All MCs	12	2.0	12	2.0	0.010	5.3	LOSA	0.0	0.2	0.15	0.54	0.15	51.8
Approach			13	2.0	13	2.0	0.010	5.3	LOSA	0.0	0.2	0.15	0.54	0.15	51.8
All Vehicles			113	2.0	113	2.0	0.030	5.5	NA	0.1	1.0	0.02	0.58	0.02	52.6

Site Level of Service (LOS) Method: Delay (SIDRA). Site LOS Method is specified in the Parameter Settings dialog (Options tab).

Vehicle movement LOS values are based on average delay per movement.

Minor Road Approach LOS values are based on average delay for all vehicle movements.

NA (TWSC): Level of Service is not defined for major road approaches or the intersection as a whole for Two-Way Sign Control (HCM LOS rule).

Two-Way Sign Control Capacity Model: SIDRA Standard.

Delay Model: SIDRA Standard (Control Delay: Geometric Delay is included).

Queue Model: SIDRA queue estimation methods are used for Back of Queue and Queue at Start of Gap.

Gap-Acceptance Capacity Formula: SIDRA Standard (Akçelik M3D).

HV (%) values are calculated for All Movement Classes of All Heavy Vehicle Model Designation.

Arrival Flows used in performance calculations are adjusted to include any Initial Queued Demand and Upstream Capacity Constraint effects.

SIDRA INTERSECTION 10.0 | Copyright © 2000-2025 Akcelik and Associates Pty Ltd | sidrasolutions.com

Organisation: RATIO CONSULTANTS PTY LTD | Licence: NETWORK / 1PC | Processed: Tuesday, 12 August 2025 6:08:38 PM

Project: C:\Users\conor.hogan\Ratio Consultants\22410T - Documents\Work\Analysis\SIDRA\22410T - SIDRA INTERSECTIONS - UPDATED ANALYSIS - RFI.sipx

# MOVEMENT SUMMARY

Site: [103] Dead Horse Lane / Withers Lane / Driveway - Post Development - PM Peak (Dead Horse Lane / Withers Lane / Driveway)

Output produced by SIDRA INTERSECTION Version: 10.0.3.210

Dead Horse Lane / Withers Lane / Driveway - Post Development - AM Peak

Site Category: (None)

Give-Way (Two-Way)

Site Scenario: 1 | Local Volumes

Vehicle Movement Performance															
Mov ID	Turn	Mov Class	Demand Flows		Arrival Flows		Deg. Satn	Aver. Delay	Level of Service	95% Back Of Queue		Prop. Qued	Eff. Stop of Cycles	Number of Cycles to Depart	Aver. Speed
			[ Total HV ]	[ Total HV ]	[ Total HV ]	[ Total HV ]	v/c	sec		[ Veh.	Dist ]		Rate	Rate	km/h
			veh/h	%	veh/h	%				veh	m				
South: Withers Lane (S)															
1a	L1	All MCs	25	2.0	25	2.0	0.039	5.3	LOSA	0.2	1.2	0.01	0.59	0.01	52.6
3	R2	All MCs	45	2.0	45	2.0	0.039	5.5	LOSA	0.2	1.2	0.01	0.59	0.01	52.5
Approach			71	2.0	71	2.0	0.039	5.4	NA	0.2	1.2	0.01	0.59	0.01	52.5
East: Dead Horse Lane															
4	L2	All MCs	37	2.0	37	2.0	0.021	5.6	LOSA	0.0	0.0	0.01	0.57	0.01	52.8
6a	R1	All MCs	1	2.0	1	2.0	0.021	5.0	LOSA	0.0	0.0	0.01	0.57	0.01	52.7
Approach			38	2.0	38	2.0	0.021	5.5	NA	0.0	0.0	0.01	0.57	0.01	52.8
NorthWest: Withers Lane (N)															
27a	L1	All MCs	1	2.0	1	2.0	0.020	5.5	LOSA	0.1	0.5	0.16	0.54	0.16	51.6
29a	R1	All MCs	23	2.0	23	2.0	0.020	5.3	LOSA	0.1	0.5	0.16	0.54	0.16	51.7
Approach			24	2.0	24	2.0	0.020	5.3	LOSA	0.1	0.5	0.16	0.54	0.16	51.7
All Vehicles			133	2.0	133	2.0	0.039	5.4	NA	0.2	1.2	0.04	0.58	0.04	52.5

Site Level of Service (LOS) Method: Delay (SIDRA). Site LOS Method is specified in the Parameter Settings dialog (Options tab).

Vehicle movement LOS values are based on average delay per movement.

Minor Road Approach LOS values are based on average delay for all vehicle movements.

NA (TWSC): Level of Service is not defined for major road approaches or the intersection as a whole for Two-Way Sign Control (HCM LOS rule).

Two-Way Sign Control Capacity Model: SIDRA Standard.

Delay Model: SIDRA Standard (Control Delay: Geometric Delay is included).

Queue Model: SIDRA queue estimation methods are used for Back of Queue and Queue at Start of Gap.

Gap-Acceptance Capacity Formula: SIDRA Standard (Akçelik M3D).

HV (%) values are calculated for All Movement Classes of All Heavy Vehicle Model Designation.

Arrival Flows used in performance calculations are adjusted to include any Initial Queued Demand and Upstream Capacity Constraint effects.

SIDRA INTERSECTION 10.0 | Copyright © 2000-2025 Akcelik and Associates Pty Ltd | sidrasolutions.com

Organisation: RATIO CONSULTANTS PTY LTD | Licence: NETWORK / 1PC | Processed: Tuesday, 12 August 2025 6:08:39 PM

Project: C:\Users\conor.hogan\Ratio Consultants\22410T - Documents\Work\Analysis\SIDRA\22410T - SIDRA INTERSECTIONS - UPDATED ANALYSIS - RFI.sipx

# MOVEMENT SUMMARY

Site: [106] Dead Horse Lane / Midland Highway - Post Development - AM Peak (Dead Horse Lane / Midland Highway)  
 Output produced by SIDRA INTERSECTION Version: 10.0.3.210

Dead Horse Lane / Midland Highway - Post Development - AM Peak  
 Site Category: (None)  
 Give-Way (Two-Way)  
 Site Scenario: 1 | Local Volumes

Vehicle Movement Performance															
Mov ID	Turn	Mov Class	Demand Flows		Arrival Flows		Deg. Satn	Aver. Delay	Level of Service	95% Back Of Queue		Prop. Qued	Eff. Stop of Cycles	Number of Cycles to Depart	Aver. Speed
			[ Total HV ]	[ Total HV ]	[ Total HV ]	[ Total HV ]	v/c	sec		[ Veh. ]	[ Dist ]		Rate		km/h
			veh/h	%	veh/h	%				veh	m				
South: Midland Highway (S)															
1	L2	All MCs	24	2.0	24	2.0	0.092	7.2	LOS A	0.4	3.0	0.18	0.40	0.18	59.4
2	T1	All MCs	63	2.0	63	2.0	0.092	0.2	LOS A	0.4	3.0	0.18	0.40	0.18	71.4
3	R2	All MCs	75	2.0	75	2.0	0.092	6.9	LOS A	0.4	3.0	0.18	0.40	0.18	59.1
Approach			162	2.0	162	2.0	0.092	4.4	NA	0.4	3.0	0.18	0.40	0.18	63.4
East: Dead Horse Lane (E)															
4	L2	All MCs	67	2.0	67	2.0	0.089	5.8	LOS A	0.3	2.5	0.23	0.55	0.23	55.2
5	T1	All MCs	24	2.0	24	2.0	0.089	5.4	LOS A	0.3	2.5	0.23	0.55	0.23	51.2
6	R2	All MCs	17	2.0	17	2.0	0.089	7.2	LOS A	0.3	2.5	0.23	0.55	0.23	55.0
Approach			108	2.0	108	2.0	0.089	5.9	LOS A	0.3	2.5	0.23	0.55	0.23	54.2
North: Midland Highway (N)															
7	L2	All MCs	8	2.0	8	2.0	0.062	7.2	LOS A	0.2	1.2	0.10	0.21	0.10	61.7
8	T1	All MCs	82	2.0	82	2.0	0.062	0.1	LOS A	0.2	1.2	0.10	0.21	0.10	74.7
9	R2	All MCs	24	2.0	24	2.0	0.062	6.9	LOS A	0.2	1.2	0.10	0.21	0.10	61.3
Approach			115	2.0	115	2.0	0.062	2.0	NA	0.2	1.2	0.10	0.21	0.10	70.3
West: Dead Horse Lane (W)															
10	L2	All MCs	34	2.0	34	2.0	0.082	5.8	LOS A	0.3	2.1	0.25	0.56	0.25	54.0
11	T1	All MCs	17	2.0	17	2.0	0.082	5.3	LOS A	0.3	2.1	0.25	0.56	0.25	50.2
12	R2	All MCs	34	2.0	34	2.0	0.082	7.5	LOS A	0.3	2.1	0.25	0.56	0.25	53.9
Approach			84	2.0	84	2.0	0.082	6.3	LOS A	0.3	2.1	0.25	0.56	0.25	53.2
All Vehicles			469	2.0	469	2.0	0.092	4.5	NA	0.4	3.0	0.18	0.41	0.18	60.4

Site Level of Service (LOS) Method: Delay (SIDRA). Site LOS Method is specified in the Parameter Settings dialog (Options tab).  
 Vehicle movement LOS values are based on average delay per movement.  
 Minor Road Approach LOS values are based on average delay for all vehicle movements.  
 NA (TWSC): Level of Service is not defined for major road approaches or the intersection as a whole for Two-Way Sign Control (HCM LOS rule).  
 Two-Way Sign Control Capacity Model: SIDRA Standard.  
 Delay Model: SIDRA Standard (Control Delay: Geometric Delay is included).  
 Queue Model: SIDRA queue estimation methods are used for Back of Queue and Queue at Start of Gap.  
 Gap-Acceptance Capacity Formula: SIDRA Standard (Akçelik M3D).  
 HV (%) values are calculated for All Movement Classes of All Heavy Vehicle Model Designation.  
 Arrival Flows used in performance calculations are adjusted to include any Initial Queued Demand and Upstream Capacity Constraint effects.

# MOVEMENT SUMMARY

Site: [107] Dead Horse Lane / Midland Highway - Post Development - PM Peak (Dead Horse Lane / Midland Highway)  
 Output produced by SIDRA INTERSECTION Version: 10.0.3.210

Dead Horse Lane / Midland Highway - Post Development - AM Peak  
 Site Category: (None)  
 Give-Way (Two-Way)  
 Site Scenario: 1 | Local Volumes

Vehicle Movement Performance															
Mov ID	Turn	Mov Class	Demand Flows		Arrival Flows		Deg. Satn	Aver. Delay	Level of Service	95% Back Of Queue		Prop. Qued	Eff. Stop of Cycles	Number of Cycles to Depart	Aver. Speed
			[ Total HV ]	[ Total HV ]	[ Total HV ]	[ Total HV ]	v/c	sec		[ Veh. ]	[ Dist ]		Rate		km/h
			veh/h	%	veh/h	%				veh	m				
South: Midland Highway (S)															
1	L2	All MCs	31	2.0	31	2.0	0.119	7.3	LOS A	0.6	3.9	0.21	0.41	0.21	59.3
2	T1	All MCs	81	2.0	81	2.0	0.119	0.3	LOS A	0.6	3.9	0.21	0.41	0.21	71.1
3	R2	All MCs	96	2.0	96	2.0	0.119	7.0	LOS A	0.6	3.9	0.21	0.41	0.21	58.9
Approach			207	2.0	207	2.0	0.119	4.4	NA	0.6	3.9	0.21	0.41	0.21	63.2
East: Dead Horse Lane (E)															
4	L2	All MCs	80	2.0	80	2.0	0.107	5.9	LOS A	0.4	3.0	0.26	0.56	0.26	54.9
5	T1	All MCs	27	2.0	27	2.0	0.107	5.8	LOS A	0.4	3.0	0.26	0.56	0.26	51.0
6	R2	All MCs	18	2.0	18	2.0	0.107	7.6	LOS A	0.4	3.0	0.26	0.56	0.26	54.7
Approach			125	2.0	125	2.0	0.107	6.1	LOS A	0.4	3.0	0.26	0.56	0.26	54.0
North: Midland Highway (N)															
7	L2	All MCs	13	2.0	13	2.0	0.078	7.3	LOS A	0.2	1.4	0.11	0.22	0.11	61.5
8	T1	All MCs	101	2.0	101	2.0	0.078	0.1	LOS A	0.2	1.4	0.11	0.22	0.11	74.3
9	R2	All MCs	28	2.0	28	2.0	0.078	7.0	LOS A	0.2	1.4	0.11	0.22	0.11	61.1
Approach			142	2.0	142	2.0	0.078	2.1	NA	0.2	1.4	0.11	0.22	0.11	70.0
West: Dead Horse Lane (W)															
10	L2	All MCs	24	2.0	24	2.0	0.088	5.8	LOS A	0.3	2.3	0.32	0.58	0.32	53.7
11	T1	All MCs	24	2.0	24	2.0	0.088	5.7	LOS A	0.3	2.3	0.32	0.58	0.32	49.9
12	R2	All MCs	33	2.0	33	2.0	0.088	8.1	LOS A	0.3	2.3	0.32	0.58	0.32	53.6
Approach			81	2.0	81	2.0	0.088	6.7	LOS A	0.3	2.3	0.32	0.58	0.32	52.5
All Vehicles			556	2.0	556	2.0	0.119	4.6	NA	0.6	3.9	0.21	0.42	0.21	60.6

Site Level of Service (LOS) Method: Delay (SIDRA). Site LOS Method is specified in the Parameter Settings dialog (Options tab).  
 Vehicle movement LOS values are based on average delay per movement.  
 Minor Road Approach LOS values are based on average delay for all vehicle movements.  
 NA (TWSC): Level of Service is not defined for major road approaches or the intersection as a whole for Two-Way Sign Control (HCM LOS rule).  
 Two-Way Sign Control Capacity Model: SIDRA Standard.  
 Delay Model: SIDRA Standard (Control Delay: Geometric Delay is included).  
 Queue Model: SIDRA queue estimation methods are used for Back of Queue and Queue at Start of Gap.  
 Gap-Acceptance Capacity Formula: SIDRA Standard (Akçelik M3D).  
 HV (%) values are calculated for All Movement Classes of All Heavy Vehicle Model Designation.  
 Arrival Flows used in performance calculations are adjusted to include any Initial Queued Demand and Upstream Capacity Constraint effects.

# MOVEMENT SUMMARY

 **Site: [110] Dead Horse Lane / Stock Route - Post Development - AM Peak** (Dead Horse Lane / Stock Route)  
 Output produced by SIDRA INTERSECTION Version: 10.0.3.210

Dead Horse Lane / Stock Route - Post Development - AM Peak  
 Site Category: (None)  
 Give-Way (Two-Way)  
**Site Scenario: 1 | Local Volumes**

Vehicle Movement Performance															
Mov ID	Turn	Mov Class	Demand Flows		Arrival Flows		Deg. Satn	Aver. Delay	Level of Service	95% Back Of Queue		Prop. Qued	Eff. Stop of Cycles	Number of Cycles to Depart	Aver. Speed
			[ Total HV ]	[ Total HV ]	[ Total HV ]	[ Total HV ]	v/c	sec		[ Veh. ]	[ Dist ]		Rate		km/h
			veh/h	%	veh/h	%				veh	m				
South: Stock Route															
1	L2	All MCs	46	2.0	46	2.0	0.086	5.6	LOS A	0.3	2.2	0.10	0.56	0.10	51.1
3	R2	All MCs	66	2.0	66	2.0	0.086	5.8	LOS A	0.3	2.2	0.10	0.56	0.10	50.8
Approach			113	2.0	113	2.0	0.086	5.7	LOS A	0.3	2.2	0.10	0.56	0.10	51.0
East: Dead Horse Lane (E)															
4	L2	All MCs	57	2.0	57	2.0	0.039	5.6	LOS A	0.0	0.0	0.00	0.46	0.00	53.7
5	T1	All MCs	16	2.0	16	2.0	0.039	0.0	LOS A	0.0	0.0	0.00	0.46	0.00	56.0
Approach			73	2.0	73	2.0	0.039	4.4	NA	0.0	0.0	0.00	0.46	0.00	54.2
West: Dead Horse Lane (W)															
11	T1	All MCs	9	2.0	9	2.0	0.031	0.2	LOS A	0.1	1.0	0.17	0.47	0.17	54.8
12	R2	All MCs	43	2.0	43	2.0	0.031	5.7	LOS A	0.1	1.0	0.17	0.47	0.17	52.4
Approach			53	2.0	53	2.0	0.031	4.7	NA	0.1	1.0	0.17	0.47	0.17	52.8
All Vehicles			238	2.0	238	2.0	0.086	5.1	NA	0.3	2.2	0.08	0.51	0.08	52.3

Site Level of Service (LOS) Method: Delay (SIDRA). Site LOS Method is specified in the Parameter Settings dialog (Options tab).  
 Vehicle movement LOS values are based on average delay per movement.  
 Minor Road Approach LOS values are based on average delay for all vehicle movements.  
 NA (TWSC): Level of Service is not defined for major road approaches or the intersection as a whole for Two-Way Sign Control (HCM LOS rule).  
 Two-Way Sign Control Capacity Model: SIDRA Standard.  
 Delay Model: SIDRA Standard (Control Delay: Geometric Delay is included).  
 Queue Model: SIDRA queue estimation methods are used for Back of Queue and Queue at Start of Gap.  
 Gap-Acceptance Capacity Formula: SIDRA Standard (Akçelik M3D).  
 HV (%) values are calculated for All Movement Classes of All Heavy Vehicle Model Designation.  
 Arrival Flows used in performance calculations are adjusted to include any Initial Queued Demand and Upstream Capacity Constraint effects.

# MOVEMENT SUMMARY

 **Site: [112] Dead Horse Lane / Stock Route - Post Development - PM Peak** (Dead Horse Lane / Stock Route)  
 Output produced by SIDRA INTERSECTION Version: 10.0.3.210

Dead Horse Lane / Stock Route - Post Development - PM Peak  
 Site Category: (None)  
 Give-Way (Two-Way)  
**Site Scenario: 1 | Local Volumes**

Vehicle Movement Performance															
Mov ID	Turn	Mov Class	Demand Flows		Arrival Flows		Deg. Satn	Aver. Delay	Level of Service	95% Back Of Queue		Prop. Qued	Eff. Stop of Cycles	Number of Cycles to Depart	Aver. Speed
			[ Total HV ]	[ Total HV ]	[ Total HV ]	[ Total HV ]	v/c	sec		[ Veh. ]	[ Dist ]		Rate		km/h
			veh/h	%	veh/h	%				veh	m				
South: Stock Route															
1	L2	All MCs	37	2.0	37	2.0	0.071	5.6	LOS A	0.3	1.8	0.10	0.56	0.10	50.8
3	R2	All MCs	55	2.0	55	2.0	0.071	5.9	LOS A	0.3	1.8	0.10	0.56	0.10	50.5
Approach			92	2.0	92	2.0	0.071	5.8	LOS A	0.3	1.8	0.10	0.56	0.10	50.7
East: Dead Horse Lane (E)															
4	L2	All MCs	68	2.0	68	2.0	0.046	5.6	LOS A	0.0	0.0	0.00	0.47	0.00	53.6
5	T1	All MCs	17	2.0	17	2.0	0.046	0.0	LOS A	0.0	0.0	0.00	0.47	0.00	55.9
Approach			85	2.0	85	2.0	0.046	4.5	NA	0.0	0.0	0.00	0.47	0.00	54.1
West: Dead Horse Lane (W)															
11	T1	All MCs	24	2.0	24	2.0	0.042	0.2	LOS A	0.2	1.4	0.18	0.40	0.18	55.5
12	R2	All MCs	47	2.0	47	2.0	0.042	5.7	LOS A	0.2	1.4	0.18	0.40	0.18	53.0
Approach			72	2.0	72	2.0	0.042	3.9	NA	0.2	1.4	0.18	0.40	0.18	53.8
All Vehicles			248	2.0	248	2.0	0.071	4.8	NA	0.3	1.8	0.09	0.48	0.09	52.7

Site Level of Service (LOS) Method: Delay (SIDRA). Site LOS Method is specified in the Parameter Settings dialog (Options tab).  
 Vehicle movement LOS values are based on average delay per movement.  
 Minor Road Approach LOS values are based on average delay for all vehicle movements.  
 NA (TWSC): Level of Service is not defined for major road approaches or the intersection as a whole for Two-Way Sign Control (HCM LOS rule).  
 Two-Way Sign Control Capacity Model: SIDRA Standard.  
 Delay Model: SIDRA Standard (Control Delay: Geometric Delay is included).  
 Queue Model: SIDRA queue estimation methods are used for Back of Queue and Queue at Start of Gap.  
 Gap-Acceptance Capacity Formula: SIDRA Standard (Akçelik M3D).  
 HV (%) values are calculated for All Movement Classes of All Heavy Vehicle Model Designation.  
 Arrival Flows used in performance calculations are adjusted to include any Initial Queued Demand and Upstream Capacity Constraint effects.

# MOVEMENT SUMMARY

**STOP** Site: [113] Maroondah Highway / Withers Lane / Kidstone Parade - Post Development - AM Peak (Maroondah Highway / Withers Lane / Kidston Parade)

Output produced by SIDRA INTERSECTION Version: 10.0.3.210

Maroondah Highway / Withers Lane / Kidstone Parade - Existing - AM Peak  
 Site Category: (None)  
 Stop (Two-Way)  
 Site Scenario: 1 | Local Volumes

Vehicle Movement Performance															
Mov ID	Turn	Mov Class	Demand Flows		Arrival Flows		Deg. Satn	Aver. Delay	Level of Service	95% Back Of Queue		Prop. Qued	Eff. Stop Rate	Number of Cycles to Depart	Aver. Speed
			[ Total HV ]	%	[ Total HV ]	%	v/c	sec		[ Veh. ]	[ Dist ]				km/h
			veh/h		veh/h					veh	m				
South: Kidston Parade															
1	L2	All MCs	23	2.0	23	2.0	0.095	8.3	LOS A	0.3	2.4	0.47	0.88	0.47	45.2
2	T1	All MCs	6	2.0	6	2.0	0.095	15.2	LOS C	0.3	2.4	0.47	0.88	0.47	39.9
3	R2	All MCs	16	2.0	16	2.0	0.095	17.2	LOS C	0.3	2.4	0.47	0.88	0.47	45.2
Approach			45	2.0	45	2.0	0.095	12.4	LOS B	0.3	2.4	0.47	0.88	0.47	44.4
East: Maroondah Highway (E)															
4	L2	All MCs	17	2.0	17	2.0	0.009	7.0	LOS A	0.0	0.0	0.00	0.63	0.00	63.9
5	T1	All MCs	155	2.0	155	2.0	0.080	0.0	LOS A	0.0	0.0	0.00	0.00	0.00	80.0
6	R2	All MCs	37	2.0	37	2.0	0.033	7.7	LOS A	0.1	0.9	0.34	0.63	0.34	51.4
Approach			208	2.0	208	2.0	0.080	1.9	NA	0.1	0.9	0.06	0.16	0.06	71.5
North: Withers Lane															
7	L2	All MCs	43	2.0	43	2.0	0.172	8.8	LOS A	0.6	4.4	0.52	0.92	0.52	45.5
8	T1	All MCs	7	2.0	7	2.0	0.172	15.5	LOS C	0.6	4.4	0.52	0.92	0.52	40.1
9	R2	All MCs	32	2.0	32	2.0	0.172	17.3	LOS C	0.6	4.4	0.52	0.92	0.52	45.5
Approach			82	2.0	82	2.0	0.172	12.7	LOS B	0.6	4.4	0.52	0.92	0.52	44.9
West: Maroondah Highway (W)															
10	L2	All MCs	24	2.0	24	2.0	0.013	7.0	LOS A	0.0	0.0	0.00	0.63	0.00	63.9
11	T1	All MCs	225	2.0	225	2.0	0.117	0.0	LOS A	0.0	0.0	0.00	0.00	0.00	79.9
12	R2	All MCs	16	2.0	16	2.0	0.013	7.3	LOS A	0.1	0.4	0.27	0.60	0.27	51.8
Approach			265	2.0	265	2.0	0.117	1.1	NA	0.1	0.4	0.02	0.09	0.02	75.7
All Vehicles			601	2.0	601	2.0	0.172	3.8	NA	0.6	4.4	0.14	0.29	0.14	64.8

Site Level of Service (LOS) Method: Delay (SIDRA). Site LOS Method is specified in the Parameter Settings dialog (Options tab).  
 Vehicle movement LOS values are based on average delay per movement.  
 Minor Road Approach LOS values are based on average delay for all vehicle movements.  
 NA (TWSC): Level of Service is not defined for major road approaches or the intersection as a whole for Two-Way Sign Control (HCM LOS rule).  
 Two-Way Sign Control Capacity Model: SIDRA Standard.  
 Delay Model: SIDRA Standard (Control Delay: Geometric Delay is included).  
 Queue Model: SIDRA queue estimation methods are used for Back of Queue and Queue at Start of Gap.  
 Gap-Acceptance Capacity Formula: SIDRA Standard (Akçelik M3D).  
 HV (%) values are calculated for All Movement Classes of All Heavy Vehicle Model Designation.  
 Arrival Flows used in performance calculations are adjusted to include any Initial Queued Demand and Upstream Capacity Constraint effects.

# MOVEMENT SUMMARY

**STOP** Site: [114] Maroondah Highway / Withers Lane / Kidstone Parade - Post Development - PM Peak (Maroondah Highway / Withers Lane / Kidston Parade)

Output produced by SIDRA INTERSECTION Version: 10.0.3.210

Maroondah Highway / Withers Lane / Kidstone Parade - Existing - AM Peak

Site Category: (None)

Stop (Two-Way)

Site Scenario: 1 | Local Volumes

Vehicle Movement Performance															
Mov ID	Turn	Mov Class	Demand Flows		Arrival Flows		Deg. Satn	Aver. Delay	Level of Service	95% Back Of Queue		Prop. Qued	Eff. Stop Rate	Number of Cycles to Depart	Aver. Speed
			[ Total HV ]	%	[ Total HV ]	%	v/c	sec		[ Veh. ]	[ Dist ]				km/h
			veh/h		veh/h					veh	m				
South: Kidston Parade															
1	L2	All MCs	27	2.0	27	2.0	0.132	8.5	LOS A	0.5	3.3	0.50	0.91	0.50	45.3
2	T1	All MCs	8	2.0	8	2.0	0.132	14.8	LOS B	0.5	3.3	0.50	0.91	0.50	39.9
3	R2	All MCs	25	2.0	25	2.0	0.132	16.5	LOS C	0.5	3.3	0.50	0.91	0.50	45.3
Approach			61	2.0	61	2.0	0.132	12.7	LOS B	0.5	3.3	0.50	0.91	0.50	44.5
East: Maroondah Highway (E)															
4	L2	All MCs	31	2.0	31	2.0	0.017	7.0	LOS A	0.0	0.0	0.00	0.63	0.00	63.9
5	T1	All MCs	187	2.0	187	2.0	0.097	0.0	LOS A	0.0	0.0	0.00	0.00	0.00	79.9
6	R2	All MCs	45	2.0	45	2.0	0.038	7.4	LOS A	0.1	1.1	0.28	0.61	0.28	51.7
Approach			263	2.0	263	2.0	0.097	2.1	NA	0.1	1.1	0.05	0.18	0.05	71.2
North: Withers Lane															
7	L2	All MCs	41	2.0	41	2.0	0.155	8.3	LOS A	0.6	4.0	0.47	0.88	0.47	45.5
8	T1	All MCs	9	2.0	9	2.0	0.155	15.0	LOS C	0.6	4.0	0.47	0.88	0.47	40.1
9	R2	All MCs	28	2.0	28	2.0	0.155	16.4	LOS C	0.6	4.0	0.47	0.88	0.47	45.6
Approach			79	2.0	79	2.0	0.155	12.0	LOS B	0.6	4.0	0.47	0.88	0.47	44.8
West: Maroondah Highway (W)															
10	L2	All MCs	35	2.0	35	2.0	0.019	7.0	LOS A	0.0	0.0	0.00	0.63	0.00	63.9
11	T1	All MCs	145	2.0	145	2.0	0.075	0.0	LOS A	0.0	0.0	0.00	0.00	0.00	80.0
12	R2	All MCs	17	2.0	17	2.0	0.015	7.5	LOS A	0.1	0.4	0.31	0.60	0.31	51.6
Approach			197	2.0	197	2.0	0.075	1.9	NA	0.1	0.4	0.03	0.16	0.03	73.3
All Vehicles			600	2.0	600	2.0	0.155	4.4	NA	0.6	4.0	0.14	0.34	0.14	63.0

Site Level of Service (LOS) Method: Delay (SIDRA). Site LOS Method is specified in the Parameter Settings dialog (Options tab).

Vehicle movement LOS values are based on average delay per movement.

Minor Road Approach LOS values are based on average delay for all vehicle movements.

NA (TWSC): Level of Service is not defined for major road approaches or the intersection as a whole for Two-Way Sign Control (HCM LOS rule).

Two-Way Sign Control Capacity Model: SIDRA Standard.

Delay Model: SIDRA Standard (Control Delay: Geometric Delay is included).

Queue Model: SIDRA queue estimation methods are used for Back of Queue and Queue at Start of Gap.

Gap-Acceptance Capacity Formula: SIDRA Standard (Akçelik M3D).

HV (%) values are calculated for All Movement Classes of All Heavy Vehicle Model Designation.

Arrival Flows used in performance calculations are adjusted to include any Initial Queued Demand and Upstream Capacity Constraint effects.

SIDRA INTERSECTION 10.0 | Copyright © 2000-2025 Akcelik and Associates Pty Ltd | sidrasolutions.com

Organisation: RATIO CONSULTANTS PTY LTD | Licence: NETWORK / 1PC | Processed: Tuesday, 12 August 2025 6:08:57 PM

Project: C:\Users\conor.hogan\Ratio Consultants\22410T - Documents\Work\Analysis\SIDRA\22410T - SIDRA INTERSECTIONS - UPDATED ANALYSIS - RFI.sipx

# Appendix G – 10-Year Post Development SIDRA Results

# MOVEMENT SUMMARY

**STOP** Site: [114 (2)] Maroondah Highway / Withers Lane / Kidstone Parade - 10 Year Growth - PM Peak (Maroondah Highway / Withers Lane / Kidston Parade)

Output produced by SIDRA INTERSECTION Version: 10.0.3.210

Maroondah Highway / Withers Lane / Kidstone Parade - Existing - AM Peak

Site Category: (None)

Stop (Two-Way)

Site Scenario: 1 | Local Volumes

Vehicle Movement Performance															
Mov ID	Turn	Mov Class	Demand Flows		Arrival Flows		Deg. Satn	Aver. Delay	Level of Service	95% Back Of Queue		Prop. Qued	Eff. Stop Rate	Number of Cycles to Depart	Aver. Speed
			[ Total HV ]	%	[ Total HV ]	%	v/c	sec		[ Veh. ]	[ Dist ]				km/h
			veh/h		veh/h					veh	m				
South: Kidston Parade															
1	L2	All MCs	27	2.0	27	2.0	0.151	8.8	LOS A	0.5	3.8	0.56	0.93	0.56	44.5
2	T1	All MCs	8	2.0	8	2.0	0.151	16.8	LOS C	0.5	3.8	0.56	0.93	0.56	39.3
3	R2	All MCs	25	2.0	25	2.0	0.151	18.9	LOS C	0.5	3.8	0.56	0.93	0.56	44.5
Approach			61	2.0	61	2.0	0.151	14.1	LOS B	0.5	3.8	0.56	0.93	0.56	43.7
East: Maroondah Highway (E)															
4	L2	All MCs	31	2.0	31	2.0	0.017	7.0	LOS A	0.0	0.0	0.00	0.63	0.00	63.9
5	T1	All MCs	228	2.0	228	2.0	0.119	0.0	LOS A	0.0	0.0	0.00	0.00	0.00	79.9
6	R2	All MCs	45	2.0	45	2.0	0.039	7.5	LOS A	0.2	1.1	0.31	0.62	0.31	51.6
Approach			304	2.0	304	2.0	0.119	1.8	NA	0.2	1.1	0.05	0.16	0.05	72.2
North: Withers Lane															
7	L2	All MCs	41	2.0	41	2.0	0.175	8.5	LOS A	0.6	4.5	0.53	0.89	0.53	44.9
8	T1	All MCs	9	2.0	9	2.0	0.175	17.1	LOS C	0.6	4.5	0.53	0.89	0.53	39.6
9	R2	All MCs	28	2.0	28	2.0	0.175	18.9	LOS C	0.6	4.5	0.53	0.89	0.53	44.9
Approach			79	2.0	79	2.0	0.175	13.3	LOS B	0.6	4.5	0.53	0.89	0.53	44.2
West: Maroondah Highway (W)															
10	L2	All MCs	35	2.0	35	2.0	0.019	7.0	LOS A	0.0	0.0	0.00	0.63	0.00	63.9
11	T1	All MCs	177	2.0	177	2.0	0.092	0.0	LOS A	0.0	0.0	0.00	0.00	0.00	80.0
12	R2	All MCs	17	2.0	17	2.0	0.015	7.7	LOS A	0.1	0.4	0.34	0.61	0.34	51.3
Approach			228	2.0	228	2.0	0.092	1.6	NA	0.1	0.4	0.03	0.14	0.03	74.1
All Vehicles			673	2.0	673	2.0	0.175	4.2	NA	0.6	4.5	0.14	0.31	0.14	64.1

Site Level of Service (LOS) Method: Delay (SIDRA). Site LOS Method is specified in the Parameter Settings dialog (Options tab).

Vehicle movement LOS values are based on average delay per movement.

Minor Road Approach LOS values are based on average delay for all vehicle movements.

NA (TWSC): Level of Service is not defined for major road approaches or the intersection as a whole for Two-Way Sign Control (HCM LOS rule).

Two-Way Sign Control Capacity Model: SIDRA Standard.

Delay Model: SIDRA Standard (Control Delay: Geometric Delay is included).

Queue Model: SIDRA queue estimation methods are used for Back of Queue and Queue at Start of Gap.

Gap-Acceptance Capacity Formula: SIDRA Standard (Akçelik M3D).

HV (%) values are calculated for All Movement Classes of All Heavy Vehicle Model Designation.

Arrival Flows used in performance calculations are adjusted to include any Initial Queued Demand and Upstream Capacity Constraint effects.

**SIDRA INTERSECTION 10.0 | Copyright © 2000-2025 Akcelik and Associates Pty Ltd | sidrasolutions.com**

Organisation: RATIO CONSULTANTS PTY LTD | Licence: NETWORK / 1PC | Processed: Tuesday, 12 August 2025 6:08:57 PM

Project: C:\Users\conor.hogan\Ratio Consultants\22410T - Documents\Work\Analysis\SIDRA\22410T - SIDRA INTERSECTIONS - UPDATED ANALYSIS - RFI.sipx

# MOVEMENT SUMMARY

Site: [106 (2)] Dead Horse Lane / Midland Highway - 10 Year Growth - AM Peak (Dead Horse Lane / Midland Highway)

Output produced by SIDRA INTERSECTION Version: 10.0.3.210

Dead Horse Lane / Midland Highway - Post Development - AM Peak

Site Category: (None)

Give-Way (Two-Way)

Site Scenario: 1 | Local Volumes

Vehicle Movement Performance															
Mov ID	Turn	Mov Class	Demand Flows		Arrival Flows		Deg. Satn	Aver. Delay	Level of Service	95% Back Of Queue		Prop. Qued	Eff. Stop of Cycles	Number of Cycles to Depart	Aver. Speed
			[ Total HV ]	[ Total HV ]	[ Total HV ]	[ Total HV ]	v/c	sec		[ Veh. ]	[ Dist ]		Rate		km/h
			veh/h	%	veh/h	%				veh	m				
South: Midland Highway (S)															
1	L2	All MCs	24	2.0	24	2.0	0.100	7.3	LOS A	0.4	3.1	0.20	0.38	0.20	59.6
2	T1	All MCs	77	2.0	77	2.0	0.100	0.2	LOS A	0.4	3.1	0.20	0.38	0.20	71.6
3	R2	All MCs	75	2.0	75	2.0	0.100	7.0	LOS A	0.4	3.1	0.20	0.38	0.20	59.2
Approach			176	2.0	176	2.0	0.100	4.1	NA	0.4	3.1	0.20	0.38	0.20	64.1
East: Dead Horse Lane (E)															
4	L2	All MCs	67	2.0	67	2.0	0.092	5.9	LOS A	0.4	2.5	0.25	0.55	0.25	55.1
5	T1	All MCs	24	2.0	24	2.0	0.092	5.6	LOS A	0.4	2.5	0.25	0.55	0.25	51.1
6	R2	All MCs	17	2.0	17	2.0	0.092	7.4	LOS A	0.4	2.5	0.25	0.55	0.25	54.9
Approach			108	2.0	108	2.0	0.092	6.0	LOS A	0.4	2.5	0.25	0.55	0.25	54.1
North: Midland Highway (N)															
7	L2	All MCs	8	2.0	8	2.0	0.072	7.2	LOS A	0.2	1.2	0.10	0.18	0.10	61.9
8	T1	All MCs	101	2.0	101	2.0	0.072	0.1	LOS A	0.2	1.2	0.10	0.18	0.10	74.9
9	R2	All MCs	24	2.0	24	2.0	0.072	7.0	LOS A	0.2	1.2	0.10	0.18	0.10	61.5
Approach			134	2.0	134	2.0	0.072	1.8	NA	0.2	1.2	0.10	0.18	0.10	71.1
West: Dead Horse Lane (W)															
10	L2	All MCs	34	2.0	34	2.0	0.085	5.8	LOS A	0.3	2.2	0.28	0.56	0.28	53.9
11	T1	All MCs	17	2.0	17	2.0	0.085	5.5	LOS A	0.3	2.2	0.28	0.56	0.28	50.1
12	R2	All MCs	34	2.0	34	2.0	0.085	7.7	LOS A	0.3	2.2	0.28	0.56	0.28	53.8
Approach			84	2.0	84	2.0	0.085	6.5	LOS A	0.3	2.2	0.28	0.56	0.28	53.1
All Vehicles			502	2.0	502	2.0	0.100	4.3	NA	0.4	3.1	0.19	0.40	0.19	61.2

Site Level of Service (LOS) Method: Delay (SIDRA). Site LOS Method is specified in the Parameter Settings dialog (Options tab).

Vehicle movement LOS values are based on average delay per movement.

Minor Road Approach LOS values are based on average delay for all vehicle movements.

NA (TWSC): Level of Service is not defined for major road approaches or the intersection as a whole for Two-Way Sign Control (HCM LOS rule).

Two-Way Sign Control Capacity Model: SIDRA Standard.

Delay Model: SIDRA Standard (Control Delay: Geometric Delay is included).

Queue Model: SIDRA queue estimation methods are used for Back of Queue and Queue at Start of Gap.

Gap-Acceptance Capacity Formula: SIDRA Standard (Akçelik M3D).

HV (%) values are calculated for All Movement Classes of All Heavy Vehicle Model Designation.

Arrival Flows used in performance calculations are adjusted to include any Initial Queued Demand and Upstream Capacity Constraint effects.

SIDRA INTERSECTION 10.0 | Copyright © 2000-2025 Akcelik and Associates Pty Ltd | sidrasolutions.com

Organisation: RATIO CONSULTANTS PTY LTD | Licence: NETWORK / 1PC | Processed: Tuesday, 12 August 2025 6:08:45 PM

Project: C:\Users\conor.hogan\Ratio Consultants\22410T - Documents\Work\Analysis\SIDRA\22410T - SIDRA INTERSECTIONS - UPDATED ANALYSIS - RFI.sipx

# MOVEMENT SUMMARY

Site: [107 (2)] Dead Horse Lane / Midland Highway - 10 Year Growth - PM Peak (Dead Horse Lane / Midland Highway)

Output produced by SIDRA INTERSECTION Version: 10.0.3.210

Dead Horse Lane / Midland Highway - Post Development - AM Peak

Site Category: (None)

Give-Way (Two-Way)

Site Scenario: 1 | Local Volumes

Vehicle Movement Performance															
Mov ID	Turn	Mov Class	Demand Flows		Arrival Flows		Deg. Satn	Aver. Delay	Level of Service	95% Back Of Queue		Prop. Qued	Eff. Stop of Cycles	Number of Cycles to Depart	Aver. Speed
			[ Total HV ]	[ Total HV ]	[ Total HV ]	[ Total HV ]	v/c	sec		[ Veh. ]	[ Dist ]		Rate		km/h
			veh/h	%	veh/h	%				veh	m				
South: Midland Highway (S)															
1	L2	All MCs	31	2.0	31	2.0	0.130	7.4	LOS A	0.6	4.2	0.23	0.39	0.23	59.4
2	T1	All MCs	99	2.0	99	2.0	0.130	0.3	LOS A	0.6	4.2	0.23	0.39	0.23	71.4
3	R2	All MCs	96	2.0	96	2.0	0.130	7.1	LOS A	0.6	4.2	0.23	0.39	0.23	59.1
Approach			225	2.0	225	2.0	0.130	4.2	NA	0.6	4.2	0.23	0.39	0.23	64.0
East: Dead Horse Lane (E)															
4	L2	All MCs	80	2.0	80	2.0	0.110	6.0	LOS A	0.4	3.1	0.29	0.57	0.29	54.8
5	T1	All MCs	27	2.0	27	2.0	0.110	6.1	LOS A	0.4	3.1	0.29	0.57	0.29	50.8
6	R2	All MCs	18	2.0	18	2.0	0.110	8.0	LOS A	0.4	3.1	0.29	0.57	0.29	54.6
Approach			125	2.0	125	2.0	0.110	6.3	LOS A	0.4	3.1	0.29	0.57	0.29	53.8
North: Midland Highway (N)															
7	L2	All MCs	13	2.0	13	2.0	0.089	7.3	LOS A	0.2	1.5	0.11	0.20	0.11	61.6
8	T1	All MCs	123	2.0	123	2.0	0.089	0.1	LOS A	0.2	1.5	0.11	0.20	0.11	74.5
9	R2	All MCs	28	2.0	28	2.0	0.089	7.1	LOS A	0.2	1.5	0.11	0.20	0.11	61.2
Approach			164	2.0	164	2.0	0.089	1.9	NA	0.2	1.5	0.11	0.20	0.11	70.7
West: Dead Horse Lane (W)															
10	L2	All MCs	24	2.0	24	2.0	0.092	5.9	LOS A	0.3	2.4	0.35	0.59	0.35	53.6
11	T1	All MCs	24	2.0	24	2.0	0.092	5.9	LOS A	0.3	2.4	0.35	0.59	0.35	49.8
12	R2	All MCs	33	2.0	33	2.0	0.092	8.4	LOS A	0.3	2.4	0.35	0.59	0.35	53.4
Approach			81	2.0	81	2.0	0.092	6.9	LOS A	0.3	2.4	0.35	0.59	0.35	52.3
All Vehicles			596	2.0	596	2.0	0.130	4.4	NA	0.6	4.2	0.22	0.40	0.22	61.3

Site Level of Service (LOS) Method: Delay (SIDRA). Site LOS Method is specified in the Parameter Settings dialog (Options tab).

Vehicle movement LOS values are based on average delay per movement.

Minor Road Approach LOS values are based on average delay for all vehicle movements.

NA (TWSC): Level of Service is not defined for major road approaches or the intersection as a whole for Two-Way Sign Control (HCM LOS rule).

Two-Way Sign Control Capacity Model: SIDRA Standard.

Delay Model: SIDRA Standard (Control Delay: Geometric Delay is included).

Queue Model: SIDRA queue estimation methods are used for Back of Queue and Queue at Start of Gap.

Gap-Acceptance Capacity Formula: SIDRA Standard (Akçelik M3D).

HV (%) values are calculated for All Movement Classes of All Heavy Vehicle Model Designation.

Arrival Flows used in performance calculations are adjusted to include any Initial Queued Demand and Upstream Capacity Constraint effects.

SIDRA INTERSECTION 10.0 | Copyright © 2000-2025 Akcelik and Associates Pty Ltd | sidrasolutions.com

Organisation: RATIO CONSULTANTS PTY LTD | Licence: NETWORK / 1PC | Processed: Tuesday, 12 August 2025 6:08:45 PM

Project: C:\Users\conor.hogan\Ratio Consultants\22410T - Documents\Work\Analysis\SIDRA\22410T - SIDRA INTERSECTIONS - UPDATED ANALYSIS - RFI.sipx

# MOVEMENT SUMMARY

**STOP** Site: [113 (2)] Maroondah Highway / Withers Lane / Kidstone Parade - 10 Year Growth - AM Peak (Maroondah Highway / Withers Lane / Kidston Parade)

Output produced by SIDRA INTERSECTION Version: 10.0.3.210

Maroondah Highway / Withers Lane / Kidstone Parade - Existing - AM Peak

Site Category: (None)

Stop (Two-Way)

Site Scenario: 1 | Local Volumes

Vehicle Movement Performance															
Mov ID	Turn	Mov Class	Demand Flows		Arrival Flows		Deg. Satn	Aver. Delay	Level of Service	95% Back Of Queue		Prop. Qued	Eff. Stop Rate	Number of Cycles to Depart	Aver. Speed
			[ Total HV ]	%	[ Total HV ]	%	v/c	sec		[ Veh. ]	[ Dist ]				km/h
			veh/h		veh/h					veh	m				
South: Kidston Parade															
1	L2	All MCs	23	2.0	23	2.0	0.111	8.5	LOS A	0.4	2.7	0.54	0.90	0.54	44.4
2	T1	All MCs	6	2.0	6	2.0	0.111	17.5	LOS C	0.4	2.7	0.54	0.90	0.54	39.2
3	R2	All MCs	16	2.0	16	2.0	0.111	20.3	LOS C	0.4	2.7	0.54	0.90	0.54	44.4
Approach			45	2.0	45	2.0	0.111	13.9	LOS B	0.4	2.7	0.54	0.90	0.54	43.6
East: Maroondah Highway (E)															
4	L2	All MCs	17	2.0	17	2.0	0.009	7.0	LOS A	0.0	0.0	0.00	0.63	0.00	63.9
5	T1	All MCs	189	2.0	189	2.0	0.098	0.0	LOS A	0.0	0.0	0.00	0.00	0.00	79.9
6	R2	All MCs	37	2.0	37	2.0	0.035	7.9	LOS A	0.1	1.0	0.38	0.64	0.38	51.1
Approach			243	2.0	243	2.0	0.098	1.7	NA	0.1	1.0	0.06	0.14	0.06	72.5
North: Withers Lane															
7	L2	All MCs	43	2.0	43	2.0	0.200	9.2	LOS A	0.7	5.1	0.58	0.94	0.58	44.6
8	T1	All MCs	7	2.0	7	2.0	0.200	18.1	LOS C	0.7	5.1	0.58	0.94	0.58	39.4
9	R2	All MCs	32	2.0	32	2.0	0.200	20.4	LOS C	0.7	5.1	0.58	0.94	0.58	44.6
Approach			82	2.0	82	2.0	0.200	14.3	LOS B	0.7	5.1	0.58	0.94	0.58	44.0
West: Maroondah Highway (W)															
10	L2	All MCs	24	2.0	24	2.0	0.013	7.0	LOS A	0.0	0.0	0.00	0.63	0.00	63.9
11	T1	All MCs	275	2.0	275	2.0	0.143	0.0	LOS A	0.0	0.0	0.00	0.00	0.00	79.9
12	R2	All MCs	16	2.0	16	2.0	0.014	7.4	LOS A	0.1	0.4	0.30	0.60	0.30	51.6
Approach			315	2.0	315	2.0	0.143	0.9	NA	0.1	0.4	0.02	0.08	0.02	76.3
All Vehicles			685	2.0	685	2.0	0.200	3.7	NA	0.7	5.1	0.13	0.26	0.13	66.0

Site Level of Service (LOS) Method: Delay (SIDRA). Site LOS Method is specified in the Parameter Settings dialog (Options tab).

Vehicle movement LOS values are based on average delay per movement.

Minor Road Approach LOS values are based on average delay for all vehicle movements.

NA (TWSC): Level of Service is not defined for major road approaches or the intersection as a whole for Two-Way Sign Control (HCM LOS rule).

Two-Way Sign Control Capacity Model: SIDRA Standard.

Delay Model: SIDRA Standard (Control Delay: Geometric Delay is included).

Queue Model: SIDRA queue estimation methods are used for Back of Queue and Queue at Start of Gap.

Gap-Acceptance Capacity Formula: SIDRA Standard (Akçelik M3D).

HV (%) values are calculated for All Movement Classes of All Heavy Vehicle Model Designation.

Arrival Flows used in performance calculations are adjusted to include any Initial Queued Demand and Upstream Capacity Constraint effects.

**SIDRA INTERSECTION 10.0 | Copyright © 2000-2025 Akcelik and Associates Pty Ltd | sidrasolutions.com**

Organisation: RATIO CONSULTANTS PTY LTD | Licence: NETWORK / 1PC | Processed: Tuesday, 12 August 2025 6:08:57 PM

Project: C:\Users\conor.hogan\Ratio Consultants\22410T - Documents\Work\Analysis\SIDRA\22410T - SIDRA INTERSECTIONS - UPDATED ANALYSIS - RFI.sipx